

Reduced Downtime and Maintenance Costs in Sandy Upstream Conditions With Serck Audco™ Plug Valves

Abstract

Lubricated plug valves are a proven solution in high-pressure gas blowdown applications as well for drain and gas manifolds in natural gas and oil fields and pipelines. The design of plug valves provides a reliable, bubble-tight seal and enables plant operators and maintenance supervisors to avoid downtime while reducing parts inventory and maintenance costs.

Challenge

At a field operated by a Middle Eastern natural gas and petroleum company, API 602 gate valves in drain and gas blowdown lines experienced frequent failures. Gate valves are a well-established technology and appropriate for a broad range of industrial applications, including high temperatures and pressures, corrosive media along with lethal, toxic and sub-zero fluids. However, after some period of operation in harsh field conditions, the valves could not close properly because debris and sand from the wells routinely would settle in the wedge of the gate valves. The field operator's solution: purchase and stock replacement valves and frequently send maintenance teams to shut down operations to swap out the valves. As costs escalated, field managers asked their equipment consultant to recommend valve solution options.

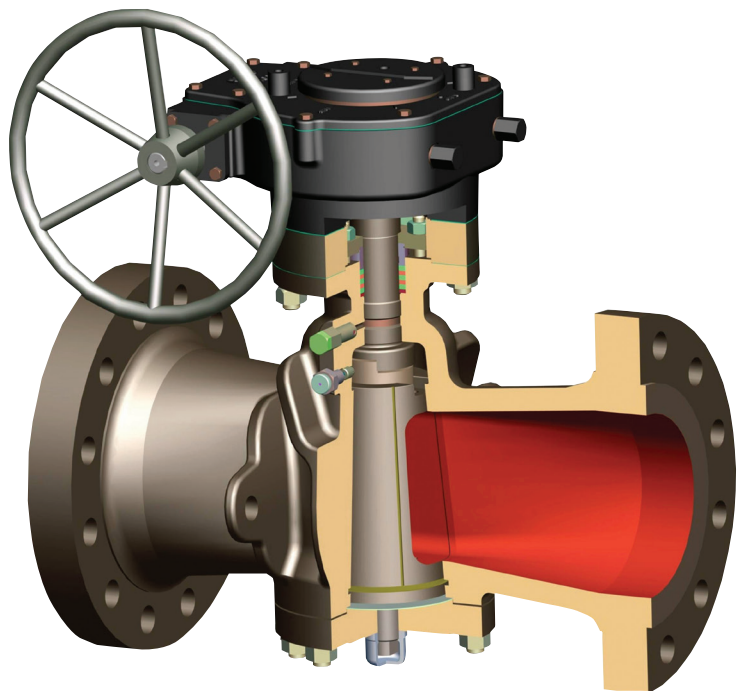



Reduced Downtime, Maintenance Costs in Sandy Upstream Conditions With Serck Audco™ Plug Valves

Solution

A casual conversation between a pipeline engineer for the equipment consultant and Flowserve representatives led to Flowserve suggesting the field operator replace the failing gate valves with Serck Audco Super-H lubricated plug valves from Flowserve. The design of plug valves prevents debris carried from a production well from blocking and closing the valve. Nevertheless, the field operator was reluctant to change their valve technology, but did agree to purchase a small number of plug valves and install them in a pilot project.

Results

In one test site, the Serck Audco Super-H plug valves from Flowserve outperformed the existing gate valves supplied by a competitor in terms of reliability. Sand and other well debris did not prevent the plug valves from closing. As a result, operational uptime improved immediately. Based on that successful test result, the field operator purchased plug valves to replace all the gate valves in sizes from 1 to 4 inches throughout the field and natural gas gathering facility.

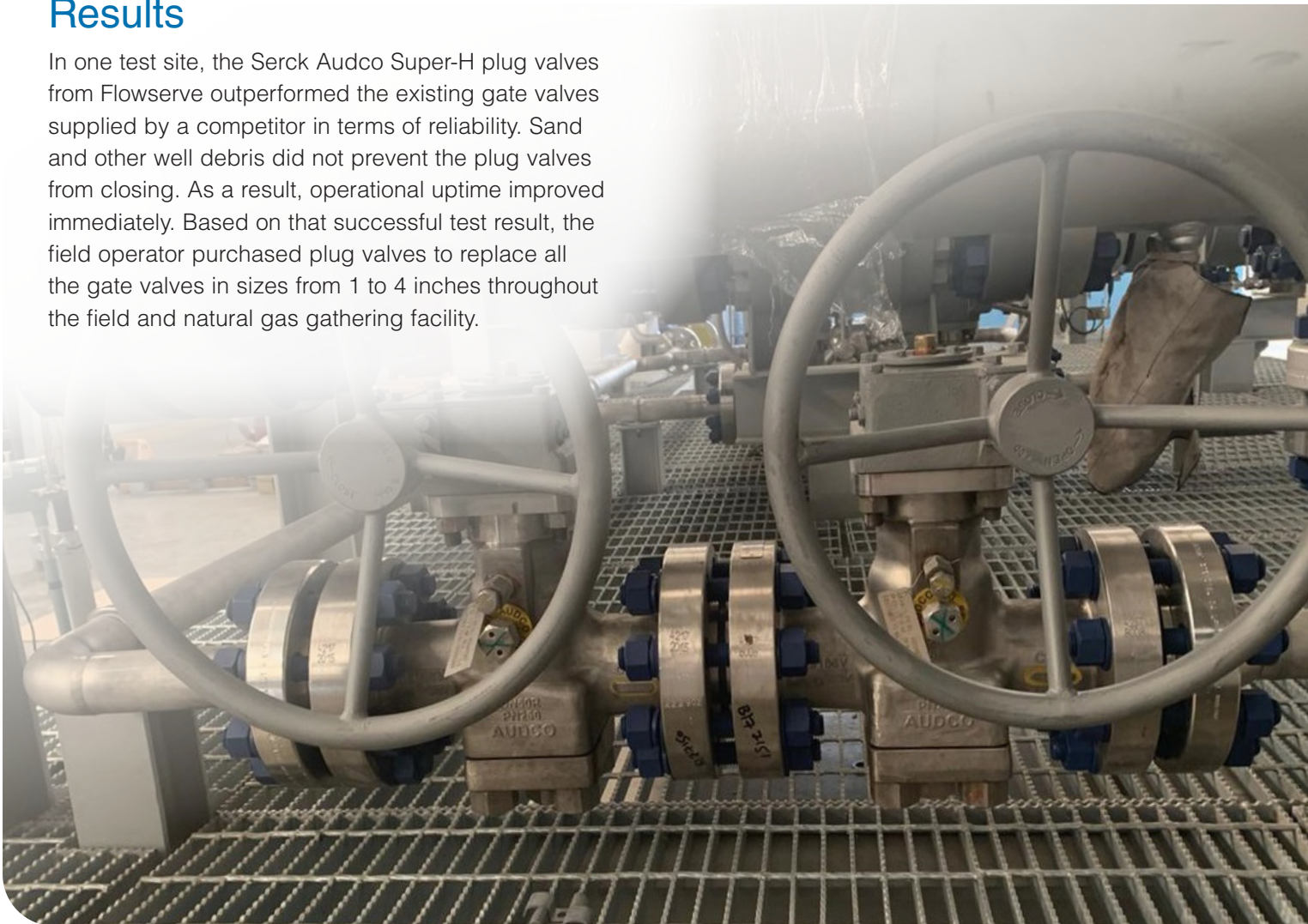



Reduced Downtime, Maintenance Costs in Sandy Upstream Conditions With Serck Audco™ Plug Valves

Conclusion

The reliability of plug valves for applications in the harshest environments compared to gate valves has been demonstrated in some of the most demanding upstream operating conditions. In upstream applications for gas fields and natural gas gathering, petroleum companies confidently can invest in lubricated plug valves instead of conventional gate valves in the following applications:

- Bleed valves in double block and bleed applications
- Gas gathering manifolds
- Gas modular skids
- Glass blowdown lines
- Off-plot, tie-in facilities skids
- Remote header lines

Serck Audco Super-H plug valves from Flowserve provide greater process control because their design ensures that complete tightness is achieved while maintaining smooth valve operation. The design also prevents sand and other well debris from obstructing closure of the plug valves.



In addition, Serck Audco Super-H plug valves are known for reliable sealing and extended service life in severe environments. Their metal-seated design stands up to high-velocity or abrasive fluids that can damage non-metallic valve seats prematurely and cause leakage that severely impacts process integrity and safety. Additionally, their quarter-turn design enables faster cycling times and simplifies automation.

Installing plug valves can result in significant savings of costs for valve procurement, stock inventory and maintenance and well as lost production during downtime.

Flowserve Corporation
5215 North O'Connor Blvd.
Suite 2300
Irving, Texas 75039-5421 USA
Telephone: +1 937 890 5839

Flowserve Corporation has established industry leadership in the design and manufacture of its products. When properly selected, this Flowserve product is designed to perform its intended function safely during its useful life. However, the purchaser or user of Flowserve products should be aware that Flowserve products might be used in numerous applications under a wide variety of industrial service conditions. Although Flowserve can provide general guidelines, it cannot provide specific data and warnings for all possible applications. The purchaser/user must therefore assume the ultimate responsibility for the proper sizing and selection, installation, operation, and maintenance of Flowserve products. The purchaser/user should read and understand the Installation Instructions included with the product, and train its employees and contractors in the safe use of Flowserve products in connection with the specific application.

While the information and specifications contained in this literature are believed to be accurate, they are supplied for informative purposes only and should not be considered certified or as a guarantee of satisfactory results by reliance thereon. Nothing contained herein is to be construed as a warranty or guarantee, express or implied, regarding any matter with respect to this product. Because Flowserve is continually improving and upgrading its product design, the specifications, dimensions and information contained herein are subject to change without notice. Should any question arise concerning these provisions, the purchaser/user should contact Flowserve Corporation at any one of its worldwide operations or offices.

©2020 Flowserve Corporation. All rights reserved. This document contains registered and unregistered trademarks of Flowserve Corporation. Other company, product, or service names may be trademarks or service marks of their respective companies.

VASS000256 (EN/A4) April 2020