

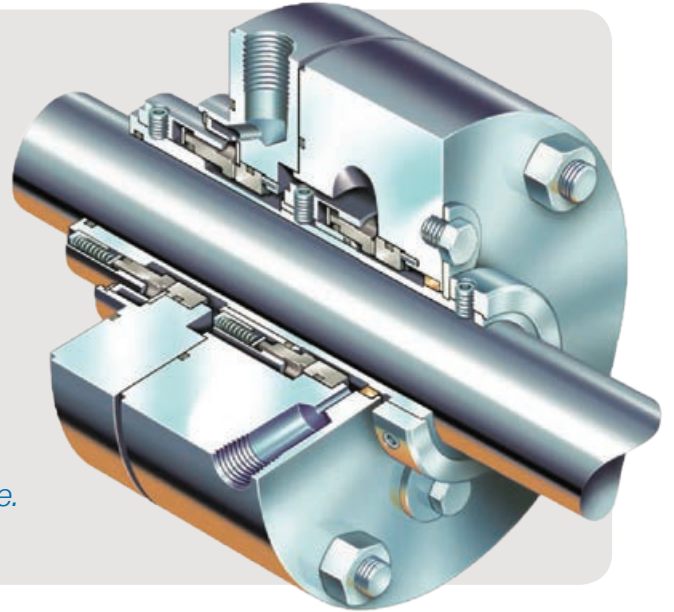

# Mechanical Seal Quick Ship

Engineered, Manufactured, Assembled,  
Tested and Shipped in 72 Hours

*Legacy mechanical seal designs pose many threats to reliable and compliant operations. Most seal suppliers offer repair and replacement of existing models within a span of several weeks, making seal improvements difficult for operators to coordinate with routine maintenance activities. Flowserve Quick Response Centers (QRCs) deliver fully engineered seal upgrades within 72 hours, allowing operators to convert to an optimized seal design during scheduled pump downtime.*



## Reduce the risks associated with outdated legacy seals

From poor environmental emissions controls to the persistent risk of equipment failure and process downtime, many legacy seal designs are unable to achieve compliance with modern industry standards. Over time, these products become more difficult to repair and replace, and many seal manufacturers have difficulty supporting outdated designs, especially for challenging applications.

As a result, operators stretch existing seal lifespans well beyond reasonable timeframe, and often wait for either seal failure or the approval to launch new capital projects to perform a proper upgrade. Too often, they settle for a rudimentary seal repair or replacement that takes the manufacturer weeks (even months) to deliver.

## Improve equipment availability and operational compliance

Flowserve QRCs allow the customer to implement comprehensive seal upgrades within 72 hours, a fraction of the time it would take for the original seal manufacturer to repair or replace it. Since the upgrade falls within the parameters of a routine pump maintenance cycle, operators can avoid new capital expenditures by including the seal upgrade within a standard maintenance/repair budget.



The seal upgrade service applies to most mechanical seal applications and delivers the following operational benefits:

- Enhanced equipment reliability for maximum process availability
- Maximized pump mean time between repairs (MTBR)
- Compliance with API mechanical seal standards (API 682)
- Improved environmental emissions controls
- Reduced maintenance costs by avoiding equipment failure
- Fast turnaround for minimum pump repair cycles
- Upgrade within standard repair activities and budgets



### Make the most of your next scheduled pump maintenance

Now that you're aware of Flowserve QRCs 72-hour seal upgrade capabilities, make plans to upgrade during your next pump maintenance cycle. Don't wait until your outdated seal fails and results in unnecessary equipment or process downtime. Take advantage of your next opportunity to ensure maximum equipment compliance, reliability and availability.

Contact your Flowserve sales representative for options to improve mechanical seal delivery and performance.



Flowserve Corporation  
5215 North O'Connor Blvd.  
Suite 2300  
Irving, Texas 75039-5421 USA  
Telephone: +1 937 890 5839

Flowserve Corporation has established industry leadership in the design and manufacture of its products. When properly selected, this Flowserve product is designed to perform its intended function safely during its useful life. However, the purchaser or user of Flowserve products should be aware that Flowserve products might be used in numerous applications under a wide variety of industrial service conditions. Although Flowserve can provide general guidelines, it cannot provide specific data and warnings for all possible applications. The purchaser/user must therefore assume the ultimate responsibility for the proper sizing and selection, installation, operation, and maintenance of Flowserve products. The purchaser/user should read and understand the Installation Instructions included with the product, and train its employees and contractors in the safe use of Flowserve products in connection with the specific application.

While the information and specifications contained in this literature are believed to be accurate, they are supplied for informative purposes only and should not be considered certified or as a guarantee of satisfactory results by reliance thereon. Nothing contained herein is to be construed as a warranty or guarantee, express or implied, regarding any matter with respect to this product. Because Flowserve is continually improving and upgrading its product design, the specifications, dimensions and information contained herein are subject to change without notice. Should any question arise concerning these provisions, the purchaser/user should contact Flowserve Corporation at any one of its worldwide operations or offices.

©2019 Flowserve Corporation. All rights reserved. This document contains registered and unregistered trademarks of Flowserve Corporation. Other company, product, or service names may be trademarks or service marks of their respective companies.

SSFLY000048-2 (EN/A4) September 2019