



DMX-RO

High-efficiency membrane feed pump for reverse osmosis processes

*Minimize operating expenses and
extend mean time between repair.*

Flowserve DMX-RO high-efficiency membrane feed pumps are engineered using the latest technologies and materials to provide long-lasting, efficient operation in reverse osmosis applications.

The DMX-RO is built for high-pressure, heavy-duty membrane feed services used typically in SWRO applications. DMX-RO pump hydraulics are designed with advanced computational fluid dynamics to provide best system performance and minimize operating expenses. The pump's comprehensive hydraulic range permits precise selection to deliver best hydraulic fit, operating efficiency and stability, all of which help to extend mean time between repair. Corrosion-resistant materials ensure long performance life without degradation.

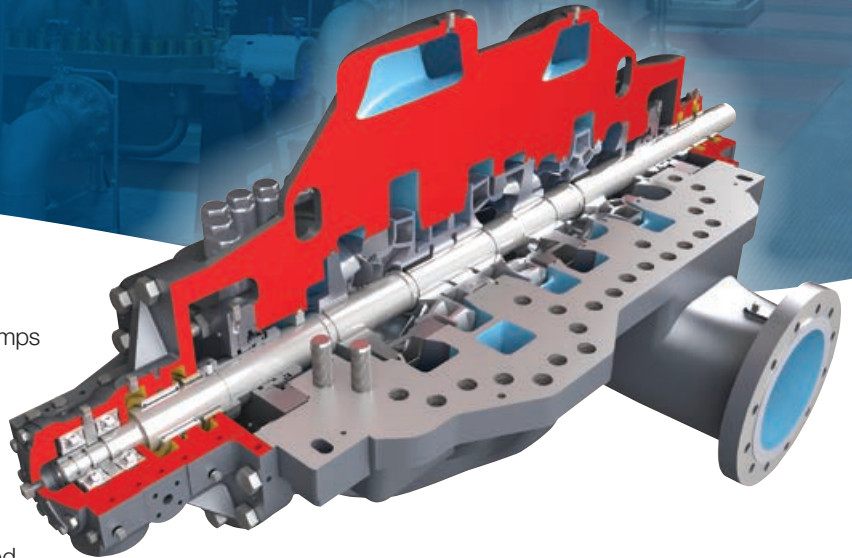

The DMX-RO is based on the widely used Flowserve DMX pump, which is fully compliant with ISO 13709/API 610 (BB3), latest edition.

Features and benefits

Axially split casing design simplifies maintenance and reduces downtime. Pump internals are easily accessed via the top casing so the bottom casing and piping connections are not disturbed.

Casing and internal material combinations selected to meet service requirements. Available materials of construction include carbon steel, chromium steel, austenitic stainless steels and super duplex stainless steels.

Nozzles are integrated with the lower half casing and designed to handle external forces and moments equal or in excess of ISO/API specified figures.

Variety of impellers and stage configurations are available.

Cap nuts are arranged on the top half casing parting flange, allowing easy casing removal for rotor inspection and maintenance.

Axially split center bushing facilitates replacement while simplifying inspection and dynamic balancing of the rotor without dismantling.

Continuous cross-over design to optimize internal losses, increase efficiency and support hydraulic balance.

Double volute construction supports radial thrust balancing.

Optimized impeller wear part clearances and careful material selection improve efficiency and maximize mean time between repair.

DMX-RO high-efficiency membrane feed pump

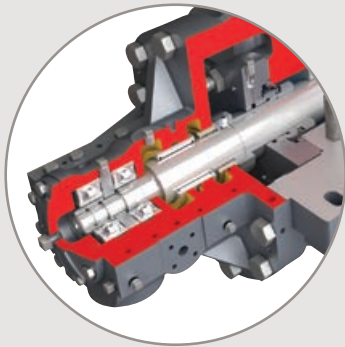

ISO 21049/API 682 seal chamber

Compliant with ISO 21049/API 682 dimensional criteria, this seal chamber design allows for installation of different cartridge types. It provides longer life and eases maintenance.

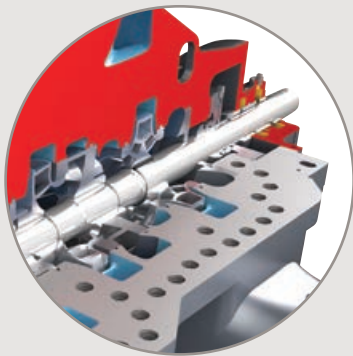

Single- or double-suction, first-stage impellers

First-stage impellers may be single- or double-suction design, depending upon NPSH available. This ensures optimal suction performance for each application.

Available pump packages

Pump packages are provided to specification and may include lube oil piping, seal systems, cooling piping Plan 11, monitoring instruments and drive train mounting.

Shaft options

The DMX-RO is available with an optional double extension for connecting to hydraulic turbines. Additionally, special shaft end machining is available for hydraulic fitted couplings.

Operating parameters

- Flows to 2950 m³/h (13,000 gpm)
- Heads to 850 m (2789 ft)
- Pressures to 90 bar (1305 psi)
- Temperatures to 50°C (34°F)
- Speeds to 3600 rpm

Materials of construction

Component	Material
Casing	Super duplex/Alloy 885
Impeller	Super duplex/Alloy 885
Shaft	Super duplex
Wear rings	Super duplex with overlay; or non-metallic
Bearing housing	Carbon steel

Flowserve Corporation
 5215 North O'Connor Blvd.
 Suite 2300
 Irving, Texas 75039-5421 USA
 Telephone: +1 937 890 5839

Flowserve Corporation has established industry leadership in the design and manufacture of its products. When properly selected, this Flowserve product is designed to perform its intended function safely during its useful life. However, the purchaser or user of Flowserve products should be aware that Flowserve products might be used in numerous applications under a wide variety of industrial service conditions. Although Flowserve can provide general guidelines, it cannot provide specific data and warnings for all possible applications. The purchaser/user must therefore assume the ultimate responsibility for the proper sizing and selection, installation, operation, and maintenance of Flowserve products. The purchaser/user should read and understand the Installation Instructions included with the product, and train its employees and contractors in the safe use of Flowserve products in connection with the specific application.

While the information and specifications contained in this literature are believed to be accurate, they are supplied for informative purposes only and should not be considered certified or as a guarantee of satisfactory results by reliance thereon. Nothing contained herein is to be construed as a warranty or guarantee, express or implied, regarding any matter with respect to this product. Because Flowserve is continually improving and upgrading its product design, the specifications, dimensions and information contained herein are subject to change without notice. Should any question arise concerning these provisions, the purchaser/user should contact Flowserve Corporation at any one of its worldwide operations or offices.

©2019 Flowserve Corporation. All rights reserved. This document contains registered and unregistered trademarks of Flowserve Corporation. Other company, product, or service names may be trademarks or service marks of their respective companies.