

Dimensions (inches)

Pump Model	A	B	C	D
50518	12.55	10.60	16.39	30.57
50523	14.63	12.68	17.43	32.65

For connection sizes/ratings and motor sizes refer to engineering data table on reverse.

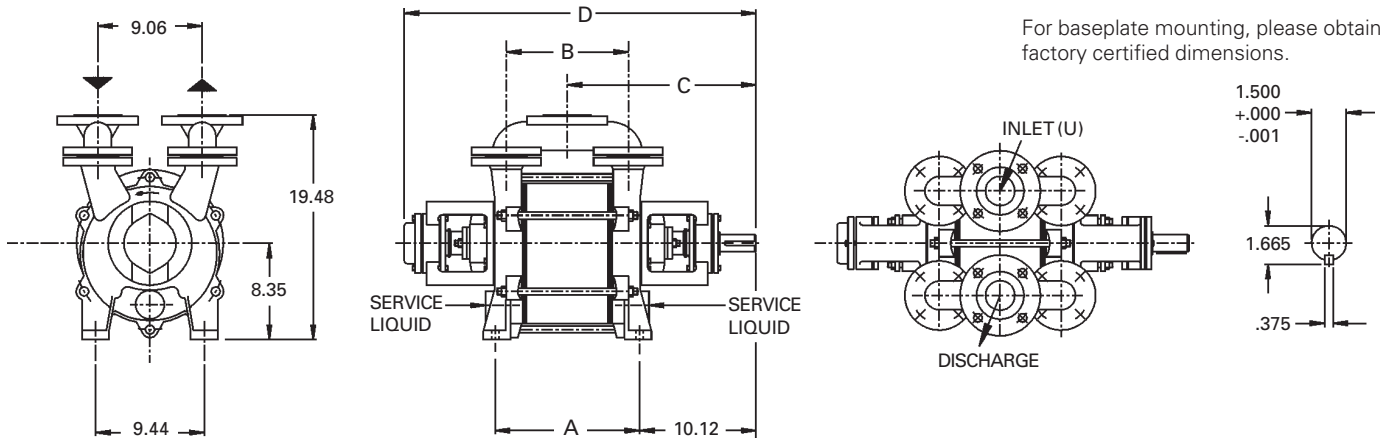

Capacity Table

Pump Model - KPH 50518												
Speed (RPM)	2 PSIG		5 PSIG		10 PSIG		15 PSIG		20 PSIG		22 PSIG	
	scfm	HP	scfm	HP	scfm	HP	scfm	HP	scfm	HP	scfm	HP
1750	247	10.0	247	14.0	245	18.5	235	22.0	214	26.0	203	27.0

Pump Model - KPH 50523												
Speed (RPM)	scfm	HP	scfm	HP	scfm	HP	scfm	HP	scfm	HP	scfm	HP
1750	300	14.0	297	18.0	290	24.0	280	29.0	257	33.0	245	34.0
1450	238	10.0	235	12.5	220	17.0	195	22.0	155	25.0	130	26.0

This data represents average values for pumps in standard materials. Capacity in cubic feet per minute free air at 68°F (20°C) using 60°F (16°C) water as a service liquid. Discharge pressure measured at the pump discharge flange.

ENGINEERING DATA

PUMP MODEL	50518	50523
Gas Conn. Size/Rating (U)	2½"/150RF	2½"/150RF
Service Liq. Line Size/Rating (U _B)	1"/NPT	1"/NPT
Cont. Drain Size/Rating (U _{se})	¼"/NPT	¼"/NPT
Motor (@ 1750 rpm) HP	30	40
Bare Pump Wt. (lb)	295	310
4 Direct Dr. Basemount (lb)	830	990
Min. V-Belt Sheave Dia.	7.9"	9.8"
T-Separator/Trap Model	Upon Request	Upon Request
Separator Size - Recirc. (Gal.)	40	40
1/2 Norm. Max. Gas Temp. (°F)	200	200
2 Max. Service Liq. Temp. (°F)	180	180
3 Sound Level (dBA)	72	72
Moment of Inertia Wr ² (lb. ft ²)	4.97	5.93
Casing Max. WP/Hydro (psi)	30/45	30/45

1. Max. gas temperature with saturated gases.
2. Higher temperatures possible on request.
3. At 3 ft., 1750 RPM w/o motor (not certified).
4. Basemount includes pump, motor, coupling, guard and base.

SERVICE LIQUID RATES (USGPM)

PUMP MODEL- KPH 50518															
Pump Speed	5 PSIG			10 PSIG			15 PSIG			20 PSIG			22 PSIG		
	A	B	C	A	B	C	A	B	C	A	B	C	A	B	C
1750	4.5	2.8	2.0	7.9	4.3	3.0	11.0	5.5	3.7	13.0	6.6	4.4	14.0	6.9	4.6
PUMP MODEL- KPH 50523															
1750	3.6	2.6	2.0	6.5	4.3	3.2	9.0	5.6	4.1	11.2	6.7	4.8	11.8	7.0	5.0
1450		2.3	1.7		3.7	2.6		5.0	3.5		6.0	4.1		6.2	4.2

Column 'A' is the flow in USGPM required - once through.
 Column 'B' is the make-up flow required when make-up water is 5°C (9°F) cooler than service water.
 Column 'C' is the make-up flow when make-up water is 10°C (18°F) cooler than service water.
 For continuous operation, the service liquid supply pressure should be at least the suction pressure, plus 80% of the differential pressure from suction to discharge.

Note: The service liquid supply pressure may vary with pump speed and discharge pressure. Please consult factory engineering department for additional information.

SECTIONAL

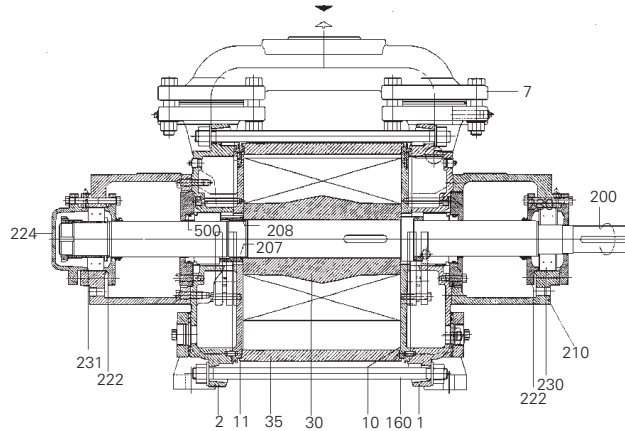

Standard rotation 'AB' (clockwise) viewed from driven end. 'AL' (counter clockwise) upon request.

PARTS LIST

- | | | |
|----------------------------------|------------------------|----------------------|
| 1. Suction Cover | 35. Centerbody | 222. Bearing Cover |
| 2. Discharge Cover | 160. Tie Bolt Assembly | 224. Bearing Cover |
| 7. Suction & Discharge Manifolds | 200. Shaft | 230. Roller Bearing |
| 10. Intermediate | 207. Impeller Nut | 231. Roller Bearing |
| 11. Intermediate | 208. Lockwasher | 500. Mechanical Seal |
| 30. Impeller | 210. Bearing Housing | |

MATERIALS

ITEM	0B	4B
Casing-Wetted	Cast Iron	316 SS
Intermediates	Cast Iron	316 SS
Impeller(s)	Ductile iron	316 SS
Shaft	420 SS QT	316 SS
Shaft Sleeves	N/A	N/A
Shaft Sealing	AAB ⁵	AAB ⁵
Casing-Non Wetted	Cast Iron	Cast Iron

⁵ AAB = single bellows seal with viton elastomers, carbon vs SiC faces