

**Argus™ FK76C  
Metal Seated, Trunnion-Mounted  
Ball Valve**

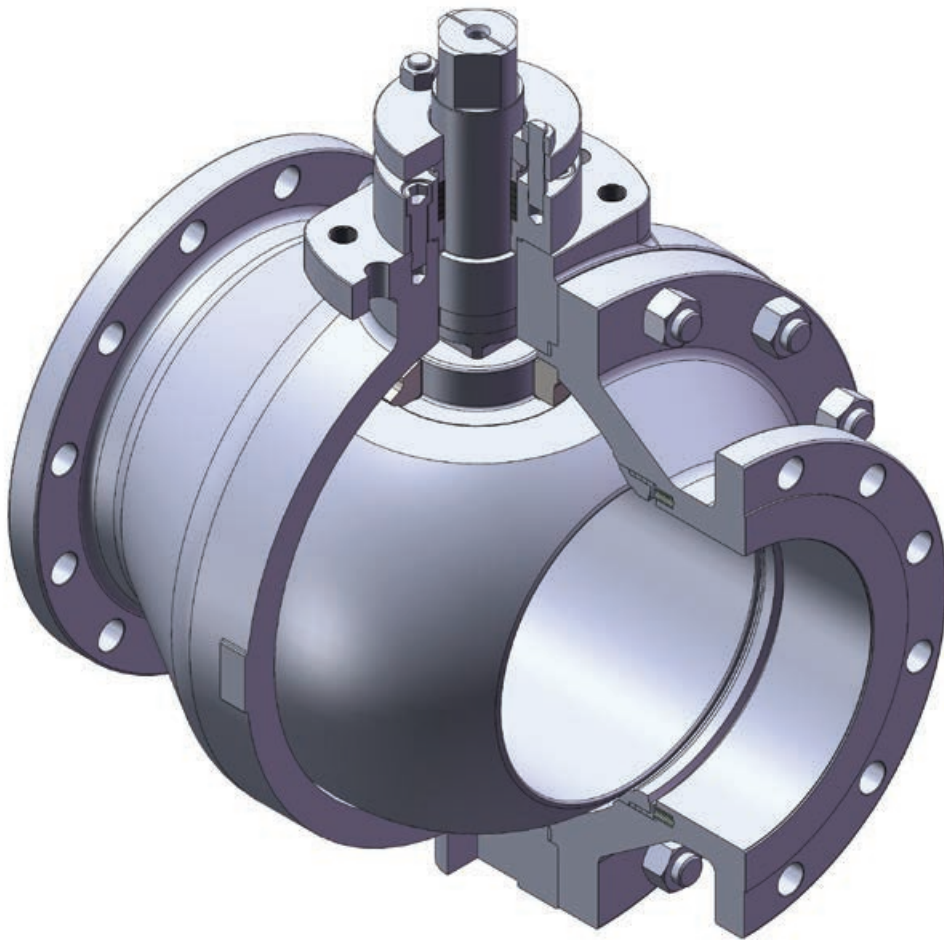

## Built to the highest standards

The FK76C split-body, full-bore, trunnion-mounted ball valve represents the highest standards in valve technology. Its superfine-finished, trunnion-mounted ball design is just one of its many important design features. Among them are an anti-blow out stem, long-life, double-stem seal system and stem supported in bearings to ensure seals are free from operation loads.

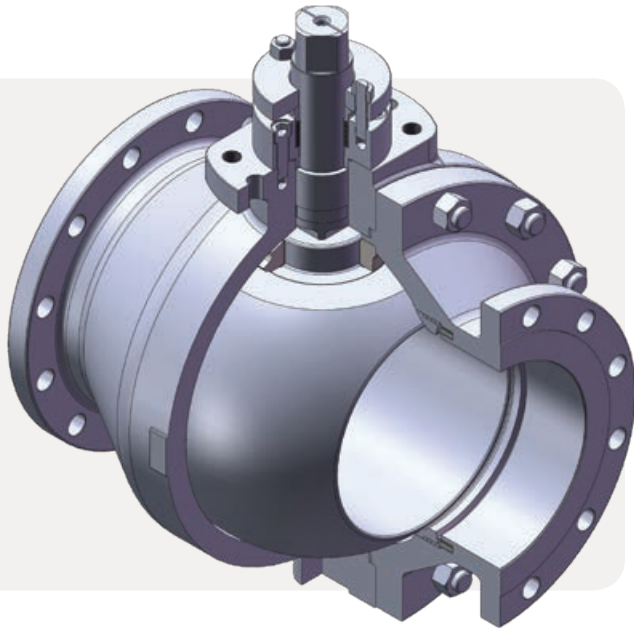

### Technical design features

- Sizes: NPS 6 – 12 in; DN 150 – 300
- ASME pressure classes: Class 150 – 300
- Valve maximum temperature: 300°C (572°F)
- Designed to: ASME B16.34 (PED 97/23/EC optional) trunnion
- Materials: ASME Section II
- Pressure/temperature rating: ASME B16.34/B16.5
- Wall thickness: ASME B16.34
- Face-to-face dimensions: ASME B16.10
- Flange connection/end type: ASME B16.5 raised face
- Fire-safe: ISO 10497
- Bi-directional, metal-to-metal sealing: ANSI B16.104, FCI 70-2 class V
- Stem sealing system: ISO 15848-1
- Anti-static design: DIN EN ISO 17292, chapter 5.2.7

### Materials

Description	NPS 6–8 in ASTM Material	DN 150–200 Material DIN EN	NPS 10–12 in ASTM Material
Body	A352 Gr. LCB	LCS casting DIN EN 1.6220	A352 Gr. LCB
	A351 Gr. CF8M	SS DIN EN 1.4408	A351 Gr. CF8M
Ball	A351 CF8M chrome plated	SS DIN 1.4408 chrome plated	A351 CF8M Crabide HVOF
Stem	A182 F51	Duplex DIN EN 1.4462	A182 F51
Stem seals	Graphite		
Seats	ASTM A182 F51 Crabide HVOF	Duplex DIN 1.4462 Crabide HVOF	ASTM A182 F51 Crabide HVOF
Body seals	Spiral-wound gasket A316L/graphite		
Bolts	A193 B7; A193 B8M CL2		
Nuts	A194 Grs. 4, 7 or 8M		

# Metal coatings

## Chrome hardplated (ball)

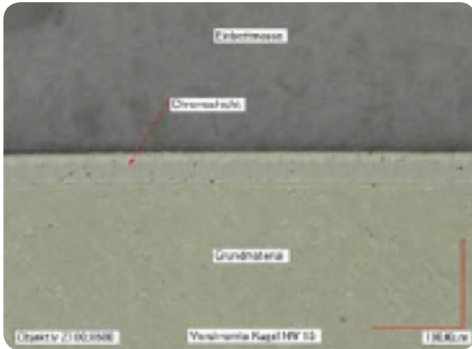

<b>Basis</b>	Chromium
<b>Hardness</b>	900 – 1100 HV0,3 (>67 HRC)
<b>Temperature limit</b>	Max. 350°C (662°F) (depending on base material and process conditions)
<b>Thickness</b>	>30 – 50 µm (average)
<b>Chemical properties</b>	High chemical resistance as well as under high temperature
<b>Mechanical properties</b>	High resistance against abrasion and adhesive wear

- Einbettmasse = embedding compound
- Chromschicht = chromium coating
- Grundmaterial = base material

## Crabide (ball and/or seats)

Crabide is a hard metal alloy based on chromium-carbide and nickel/chromium.

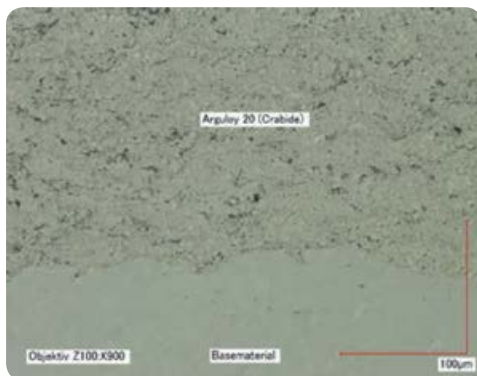

<b>Composition</b>	$Cr_2C_2$ /Ni-Cr 75/25
<b>Hardness</b>	900 – 1100 HV0,3 (>67 HRC)
<b>Temperature limit</b>	Max. 660°C (1112°F) (depending on base material and process conditions)
<b>Thickness</b>	200 – 300 µm (usual)
<b>Chemical properties</b>	Resistance versus media in the range of pH 5 to pH 12, as well under high-temperature conditions
<b>Mechanical properties</b>	High resistance, especially against abrasion and adhesive wear and sliding abrasion

# Sectional drawing

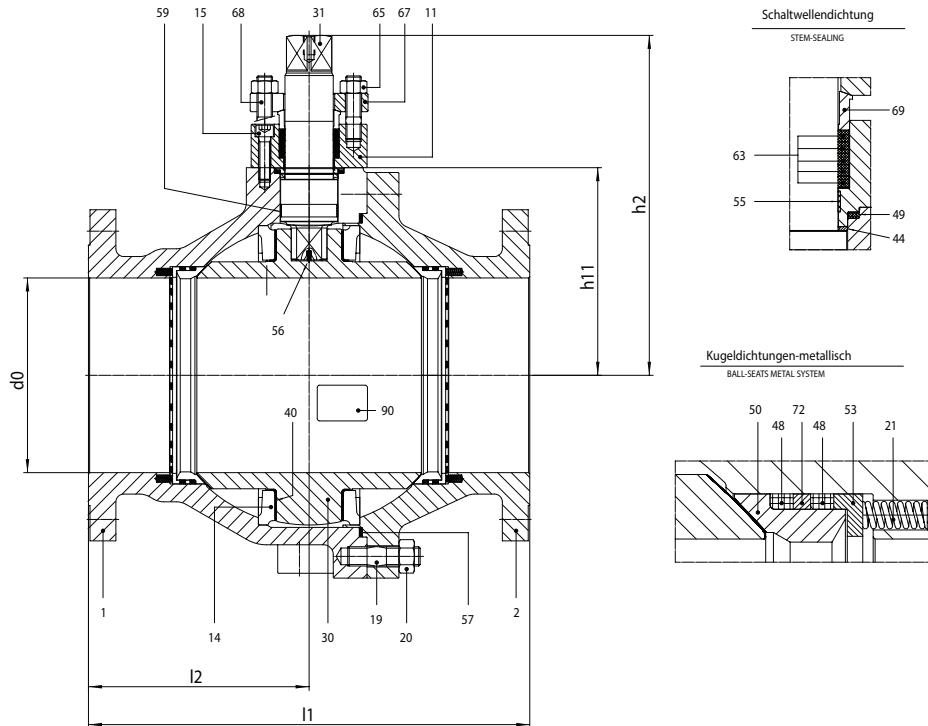

## Dimensions

### ASME Class 150 mm (in)

DN (NPS)	Flange/End Type	l1	l2	h2	h1	d0	Topwork DIN/ISO 5211
150 (6)	RF	394 (15.51)	197 (7.76)	317 (12.48)	180 (7.09)	150 (5.91)	Note 1
200 (8)	RF	457 (17.99)	228.5 (9.00)	352 (13.86)	215 (8.46)	201.6 (7.94)	
250 (10)	RF	533 (20.98)	266.5 (10.49)	446.5 (17.58)	290 (11.42)	254 (10.00)	
300 (12)	RF	610 (24.02)	305 (12.01)	483.5 (19.04)	327 (12.87)	305 (12.01)	

### ASME Class 300 mm (in)

DN (NPS)	Flange/End Type	l1	l2	h2	h1	d0	Topwork DIN/ISO 5211
150 (6)	RF	403 (15.87)	201.5 (7.93)	317 (12.48)	180 (7.09)	150 (5.91)	Note 1
200 (8)	RF	502 (19.76)	251 (9.88)	352 (13.86)	215 (8.46)	201 (7.91)	
250 (10)	RF	568 (22.36)	284 (11.18)	446.5 (17.58)	290 (11.42)	254 (10.00)	
300 (12)	RF	648 (25.51)	324 (12.76)	483.5 (19.04)	327 (12.87)	305 (12.01)	

## Pressure/temperature rating per ASME B16.34

Temperature, °F	A352 Gr. LCB		A351 Gr. CF8M	
	Working Pressures by Class, psig		Working Pressures by Class, psig	
	Class 150	Class 300	Class 150	Class 300
-20 to 100	265	695	275	720
200	255	660	235	620
300	230	640	215	560
400	200	615	195	515
500	170	585	170	480
600	140	550	140	450

Temperature, °C	A352 Gr. LCB		A351 Gr. CF8M	
	Working Pressures by Class, bar		Working Pressures by Class, bar	
	Class 150	Class 300	Class 150	Class 300
-29 to 38	18.4	48.0	19.0	49.6
50	18.2	47.05	18.4	48.1
100	17.4	45.3	16.2	42.2
150	15.8	43.9	14.8	38.5
200	13.8	42.5	13.7	35.7
250	12.1	40.8	12.1	33.4
300	10.2	38.7	10.2	31.6

### Part numbers

#### ASME Class 150

NPS	Class	Ends	Body	Sectional	Assembly	Topwork	Valve number	
6	150	RF	CS	4M0985	4M4839	3Z2095	765617-ETG	
8	150			4M0986	4M4841	3Z2095	765621-ETG	
10	150			4M1022	4M4904	3Z2102	765625-ETG	
12	150			4M1023	4M4906	3Z2102	765629-ETG	
6	300			4M0985	4M0840	3Z2095	765618-ETG	
8	300			4M0986	4M4842	3Z2095	765622-ETG	
10	300		4M1022	4M4905	3Z2102	765626-ETG		
12	300		4M1023	4M4907	3Z2102	795630-ETG		
6	150		SS		4M0985	4M4839	3Z2095	765455-ETG
8	150				4M0986	4M4841	3Z2095	765459-ETG
10	150				4M1022	4M4904	3Z2102	765627-ETG
12	150				4M1023	4M4906	3Z2102	765631-ETG
6	300	4M0985			4M0840	3Z2095	765456-ETG	
8	300	4M0986			4M4842	3Z2095	765460-ETG	
10	300	4M1022			4M4905	3Z2102	765628-ETG	
12	300	4M1023			4M4907	3Z2102	765632-ETG	

# Standard Topwork drawings

FK76C Topwork drawing 3Z2095

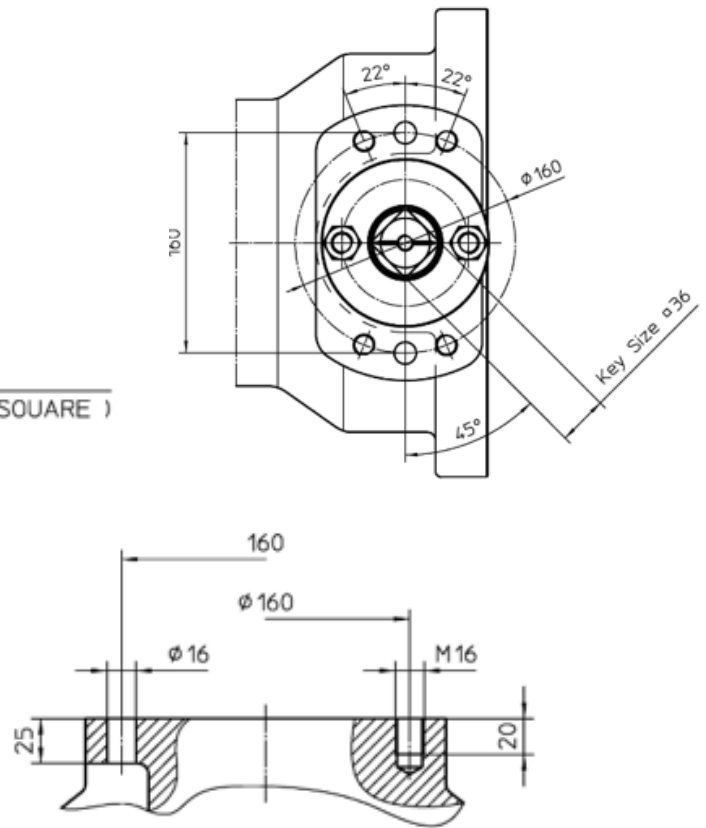
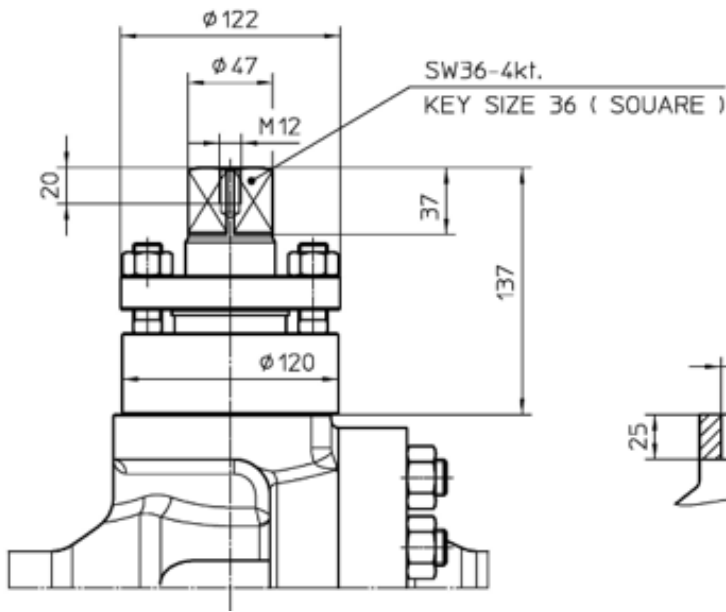

FK76C Topwork drawing 3Z2102

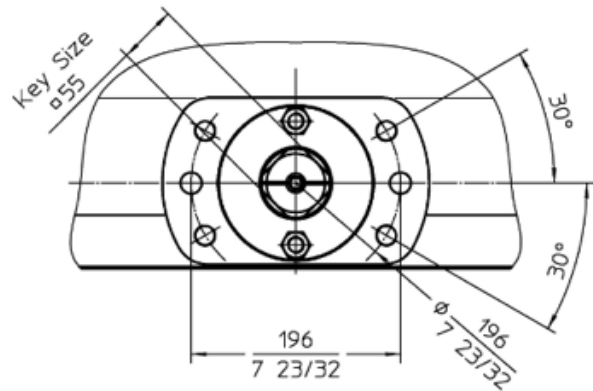
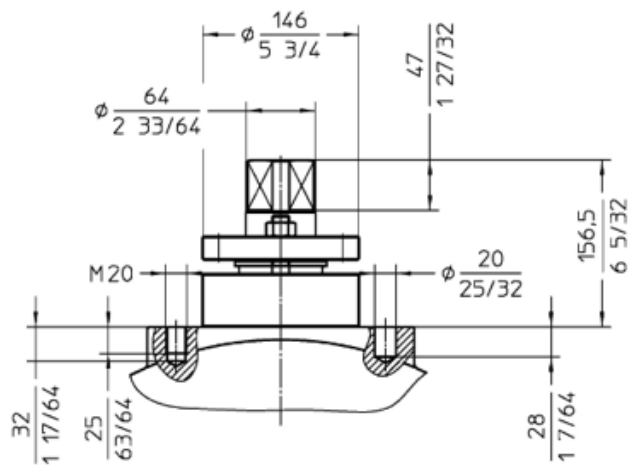

## Torque tables

**Pressure Class:** Class 150 and Class 300

**Seat System:** bidirectional "N"

Pressure (psi)	NPS 6 (lb-in)	NPS 8 (lb-in)	NPS 10 (lb-in)	NPS 12 (lb-in)
116	3018	5062	10 036	13 700
145	3310	5558	10 355	15 134
181	3664	6186	11788	16 727
232	4168	7071	13063	18 320
290	4744	8071	15134	20 390
363	5452	9328	17 523	23 576
464	6461	11 089	19 913	27 081
580	7602	13 098	24 214	31 541
725	9036	15 611	27 878	38 232

**Pressure Class:** Class 150 and Class 300

**Seat System:** bidirectional "N"

Pressure bar	DN 150 (Nm)	DN 200 (Nm)	DN 250 (Nm)	DN 300 (Nm)
8	341	572	1134	1548
10	374	628	1170	1710
12,5	414	699	1332	1890
16	471	799	1476	2070
20	536	912	1710	2304
25	616	1054	1980	2664
32	730	1253	2250	3060
40	859	1480	2736	3564
50	1021	1764	3150	4320

### Values included

- Metal seated: Chrome/Crabide and Crabide/Crabide
- Stem sealing system: ISO 15848

### Additional multiplication factors

#### Application

- Daily operation: 1.0
- Operation after longer periods of disuse ( $\geq 2$  days): 1.1
- Operation after longer periods of disuse ( $\geq 5$  days): 1.2

#### Media

- Lubricating: 1.0
- Non-lubricating: 1.3

#### Example

DN100/differential pressure 32 bar/operation every 3 days/lubricating media

$$Md = 501 \text{ Nm} \times 1.1 \times 1.0 = 551 \text{ Nm}$$



## **USA**

### **Headquarters**

Flowserve Corporation  
5215 North O'Connor Blvd.  
Suite 2300  
Irving, Texas 75039-5421 USA  
Phone: +1 937 890 5839

Flowserve Corporation  
3993 W. Sam Houston Parkway North  
Suite 100  
Houston, TX 77043  
Phone: +1 281 469 4166

Flowserve Corporation  
1978 Foreman Drive  
Cookeville, TN 38501  
Phone: +1 931 432 4021

### **Europe**

Flowserve Flow Control GmbH  
Rudolf-Plank-Straße 2  
D-76275  
Ettlingen, Germany  
Phone: +49 7243 103-0  
Fax: +49 7243 103-222

Flowserve Corporation has established industry leadership in the design and manufacture of its products. When properly selected, this Flowserve product is designed to perform its intended function safely during its useful life. However, the purchaser or user of Flowserve products should be aware that Flowserve products might be used in numerous applications under a wide variety of industrial service conditions. Although Flowserve can provide general guidelines, it cannot provide specific data and warnings for all possible applications. The purchaser/user must therefore assume the ultimate responsibility for the proper sizing and selection, installation, operation, and maintenance of Flowserve products. The purchaser/user should read and understand the Installation Instructions included with the product, and train its employees and contractors in the safe use of Flowserve products in connection with the specific application.

While the information and specifications contained in this literature are believed to be accurate, they are supplied for informative purposes only and should not be considered certified or as a guarantee of satisfactory results by reliance thereon. Nothing contained herein is to be construed as a warranty or guarantee, express or implied, regarding any matter with respect to this product. Because Flowserve is continually improving and upgrading its product design, the specifications, dimensions and information contained herein are subject to change without notice. Should any question arise concerning these provisions, the purchaser/user should contact Flowserve Corporation at any one of its worldwide operations or offices.

©2019 Flowserve Corporation. All rights reserved. This document contains registered and unregistered trademarks of Flowserve Corporation. Other company, product, or service names may be trademarks or service marks of their respective companies.

**ARENTB0011-01 (A4)** January 2019