

Tandem Seal**1 Equipment Check**

- 1.1 Follow plant safety regulations prior to equipment disassembly:
 - 1.1.1 Wear designated personal safety equipment
 - 1.1.2 Isolate equipment and relieve any pressure in the system
 - 1.1.3 Lock out equipment driver and valves
 - 1.1.4 Consult plant Safety Data Sheet (SDS) files for hazardous material regulations
- 1.2 Disassemble equipment in accordance with the equipment manufacturer's instructions to allow access to seal installation area.
- 1.3 Remove existing sealing arrangement (mechanical seal or otherwise).
Clean seal chamber and shaft thoroughly.
- 1.4 Inspect surfaces under gaskets to ensure they are free from pits or scratches. Break all sharp corners on shaft steps, threads, reliefs, shoulders, key ways, etc. over which gasket(s) must pass and/or seal against.
- 1.5 Check shaft or sleeve OD, seal chamber bore, seal chamber depth, gland pilot, stud diameter, stud bolt pattern and distance to first obstruction to ensure they are dimensionally the same as shown in the seal assembly drawing.
- 1.6 Check seal assembly drawings for any modifications (reworks) to be made to the equipment for mechanical seal installation and act accordingly.
- 1.7 The equipment must be earthed to prevent sparks due to static electricity discharge.

Shaft runout should be checked against the equipment manufacturer's specifications. Generally, should not exceed 0.05 mm (0.002 inch) TIR (Total Indicator Reading) at any point along the shaft for ball or roller type bearings. For sleeve type bearings, refer to manufacturer instructions. If the equipment is not completely dismantled, verify runout near seal location.

The above values apply to shaft speeds in the range from 1000 to 3600 RPM. For values above and below, consult your Flowserve representative. See Figure 1.

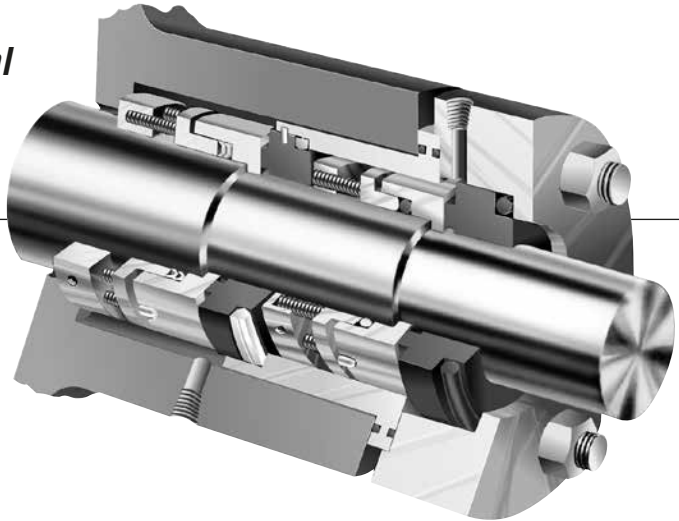
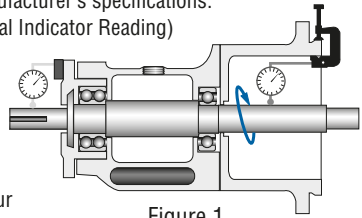

Figure 1

Shaft endplay should not exceed 0.25 mm (0.010 inch) TIR, regardless of thrust bearing type. See Figure 2.

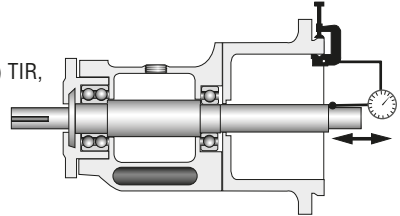

Figure 2

Maximum dynamic shaft deflection at seal chamber face should be checked against the equipment manufacturer's specifications. Generally 0.05 - 0.10 mm (0.002 - 0.004 inch) will be applicable for ball or roller type bearings. For sleeve or journal type bearings, values will generally be in the order of 0.10 - 0.15 mm (0.004 - 0.006 inch).

Seal chamber squareness to the shaft centerline should be within 0.0005 mm/mm (0.0005 inch/inch) of seal chamber bore TIR.

Note: make sure that shaft endplay does not affect the reading. Verify the smoothness of the seal chamber face for a good gasket joint. See Figure 3.

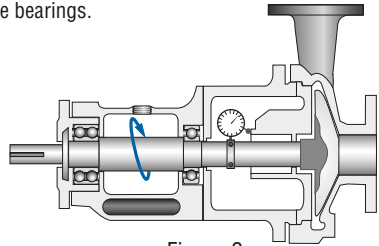

Figure 3

Concentricity of the shaft to the seal chamber bore or gland pilot register should be within 0.025 mm per 25 mm shaft diameter (0.001 inch per 1 inch shaft diameter) to a maximum of 0.125 mm (0.005 inch) TIR. See Figure 4.

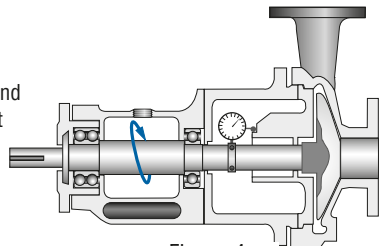
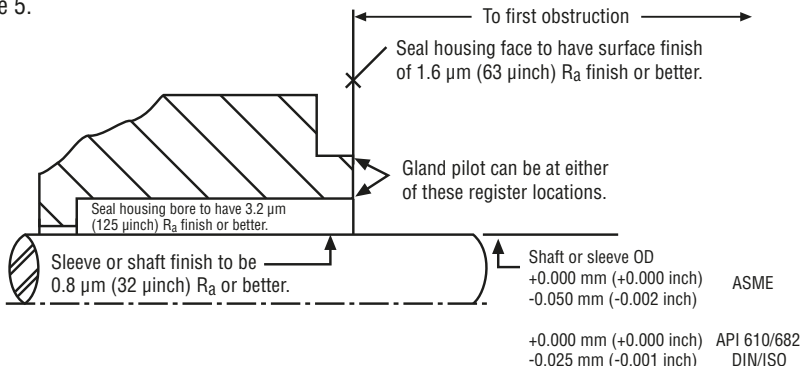

Figure 4

Surface finish requirements

Figure 5.



2 Tandem Seal Installation

- 2.1 All Tandem Seal types are a combination of two single seals. See Figure 6. Various combinations of seal types may be used to comprise a Flowserve Tandem. Other variations may include change in rotary face gasket materials and the type of mounting for the stationary faces.

Typical Tandem Dura Seal

Figure 6

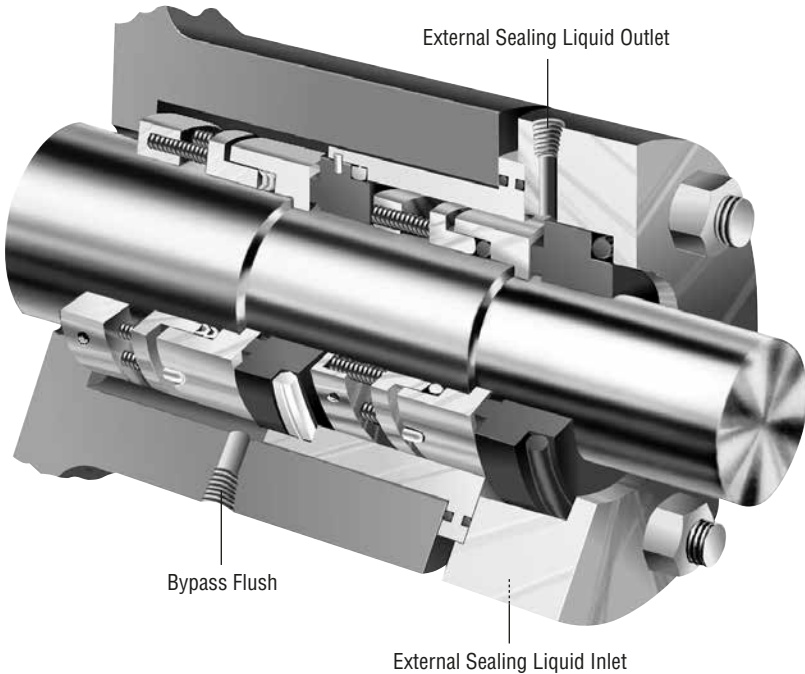

- 2.2 Scribe a mark **A** on the shaft or shaft sleeve exactly flush with the face of the seal chamber. This will be the “reference mark” for setting the seal to the seal assembly drawing. See Figure 5.
- 2.3 Refer to the assembly drawing provided with the seal for seal drive dimension settings shown in a **box**. Scribe marks **B** and **C** to locate the inner edge of the seal drive collar **17** for the outer and inner seals. See Figure 5.
- 2.4 Carefully place the gland ring **11** and the outer stationary face **14** over the shaft. Do not bump carbon parts against the shaft as they may chip, crack or break.

The images of parts shown in these instructions may differ visually from the actual parts due to manufacturing processes that do not affect the part function or quality.

Note: If the rotary units and rotating face gaskets for the inner and outer seals are to be assembled on a shaft sleeve, proceed as follows:

- 2.5 Place the seal chamber liner (155) over the shaft and into its proper position in the gland ring as shown on the seal assembly drawing.
- 2.6 Lubricate the sleeve lightly with silicone lubricant before installing any of the rotary unit parts.
- 2.7 Install the seal assembly (175) for the inner seal on the sleeve and locate the seal drive collar (2) in relation to the established scribe mark **C**, the setting dimension given on the seal assembly drawing. Lock the seal drive to the sleeve by tightening the set screws (57).
- 2.8 Place the rotating face (15) and rotating face gasket (76) for the inner seal on the sleeve and in its proper position as shown. (Duraflon® rotating face gasket should be installed on the sleeve individually and with care to avoid nicks or damage that could cause a leak.)
- 2.9 Place the stationary face (14) and seat gasket (13) for the inner seal on the sleeve.
- 2.10 Wipe the face of the rotating and stationary face clean with alcohol.
- 2.11 Install the seal assembly (175) and/or seal drive collar (2) for the outer seal on the sleeve and locate the seal drive collar (2) at the established scribe mark **B**. Lock the seal drive to the sleeve by tightening the set screws (57).
- 2.12 Place the rotating face (15) and rotating face gasket (76) for the outer seal on the sleeve and in its proper position as shown. (Duraflon® rotating face gasket should be installed on the sleeve individually and with care to avoid nicks or damage that could cause a leak.)
- 2.13 Wipe the face of the rotating and stationary faces clean with alcohol.

Note: If the outer seal is mounted on the shaft rather than on the shaft sleeve, it will be necessary to substitute the following installation instructions for the above:

- 2.11A Place the outer rotating face (15) and rotating face gasket (76) on the shaft and in its proper position. (Duraflon® rotating face gasket should be installed individually and with care to avoid nicks and damage that could cause a leak.)
- 2.12A Wipe the face of the rotating and stationary faces clean with alcohol.
- 2.13A Install the seal assembly (175) and/or seal drive collar (2) for the outer seal on the shaft and locate the seal drive collar at the established scribe mark **B**. Lock the seal drive to the shaft by tightening the set screws (57). Then place the seal chamber liner (155) over the shaft and into its proper position in the gland ring as shown on the seal assembly drawing.
- 2.14 While placing the sleeve into its proper position over the shaft, position the inner stationary face (14) into the seal chamber liner (155), making sure to align the stationary face holding pin with the slot or hole in the seal chamber liner if one is included.
- 2.15 Seat the gland ring (11) and gland ring gasket (18) to the face of the seal chamber by tightening the nuts or bolts evenly. Be sure the gland ring is not cocked and tighten the nuts or bolts only enough to seal at the gland ring gasket. Excessive tightening of the gland ring nuts or bolts will cause distortion that will be transmitted to the running faces. Follow proper gland gasket torquing instructions.

3 Operational Recommendations

- 3.1 The outer seal must be supplied with an external sealing buffer liquid. This buffer should be introduced to the cavity between the inner and outer seals and circulated by forced circulation (Figure 7) at a pressure below the primary seal chamber pressure.
- 3.2 Flowserve Corporation manufactures both packaged circulation systems and components, Figure 8. Contact your nearest Flowserve representative.
- 3.3 Be sure the sealing liquid to the outer seal is available and all environmental controls for the inner seal are operational before starting the process equipment.
- 3.4 If the seal is running hot, check to see that the gland ring is not rubbing the shaft. These clearances can be checked by using a feeler gauge.
- 3.5 If there is a leakage at the gland on start-up, it may be corrected by adjusting the gland for better alignment.

4 Repairs

This product is a precision sealing device. The design and dimension tolerances are critical to seal performance. Only parts supplied by Flowserve should be used to repair a seal. These are available from numerous Flowserve stocking locations. To order replacement parts, refer to the part code number and B/M number. A spare back-up seal should be stocked to reduce repair time.

The following parts can also be stocked for emergency needs.

- | | |
|-------------------|-------------------------|
| ⑭ Stationary face | ⑮ Springs |
| ⑰ Rotating face | ⑱ Gland gaskets |
| ⑲ Seat gaskets | ⑳ Rotating face gaskets |
| | ㉑ Set screws |

When seals are returned to Flowserve for repair, **decontaminate the seal assembly** and include an order marked "**Repair or Replace.**" **A signed certificate of decontamination** must be attached.

A Safety Data Sheet (SDS) must be enclosed for any product that came in contact with the seal. The seal assembly will be inspected and, if repairable, it will be rebuilt, tested, and returned.

API Plan 52

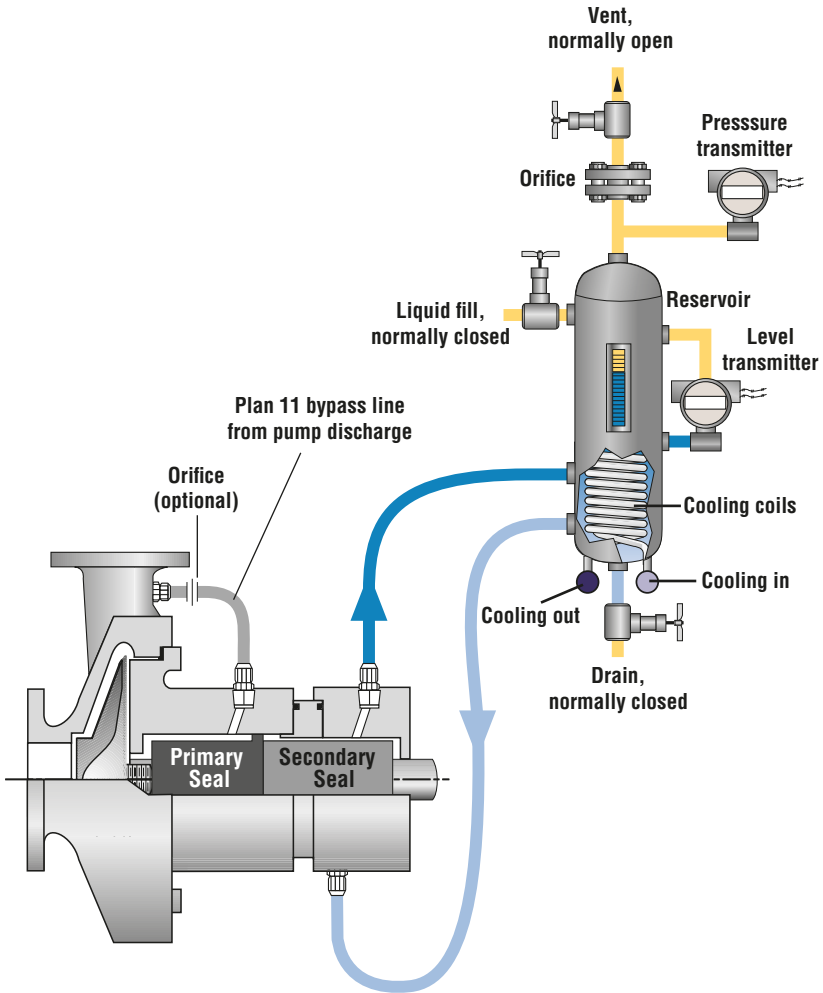

1. Solenoid valve in drain is normally open allowing primary seal weepage to vent through orifice.
2. If primary seal leakage becomes excessive, the pressure switch in the secondary seal thermal convection loop will activate alarm and close solenoid valve in the drain line.
3. Bypass line around solenoid valve is normally closed but is used to bleed system pressure.

5 Tandem Sealing Systems for Supply Tanks

Pre-engineered and assembled for safe, reliable handling of toxic, flammable, carcinogenic, or other reactive organic compounds. A tandem seal configuration is used when a back-up safety seal is required, usually in critical process pumps. But tandem seal arrangements produce weepage across the face of the primary seal. When pumping a hazardous fluid, this weepage should not be vented to the atmosphere. Containment and disposal must be a safe, controlled process. Flowserve's supply tank with the tandem sealing system (TSS) is the ideal solution.

Operation

During normal operation of the tandem sealing system, potentially hazardous seal weepage is vented to a safe disposal. In the event of a primary seal leak or failure, as the secondary seal takes over, pressure builds up across the orifice at the top of the supply tank assembly. This buildup is then detected by the pressure switch which activates an alarm. A signal from the pressure switch also closes the vent solenoid valve to isolate the hazardous vapor flow until orderly process shutdown and maintenance can be performed. (See Figure 7) Included in the tandem sealing system option are a pressure gage, pressure switch, solenoid valve, globe valves, armored level gage, and orifice.

Models available

Supply tank models for use with tandem sealing systems are made from heavy duty 304 stainless steel with pressure ratings of 2760 kPa (400 psig) or 6200 kPa (900 psig), and from carbon steel with a rating of 6200 kPa (900 psig). Order with or without cooling coils.

Plan 52 Supply Tank

Figure 8

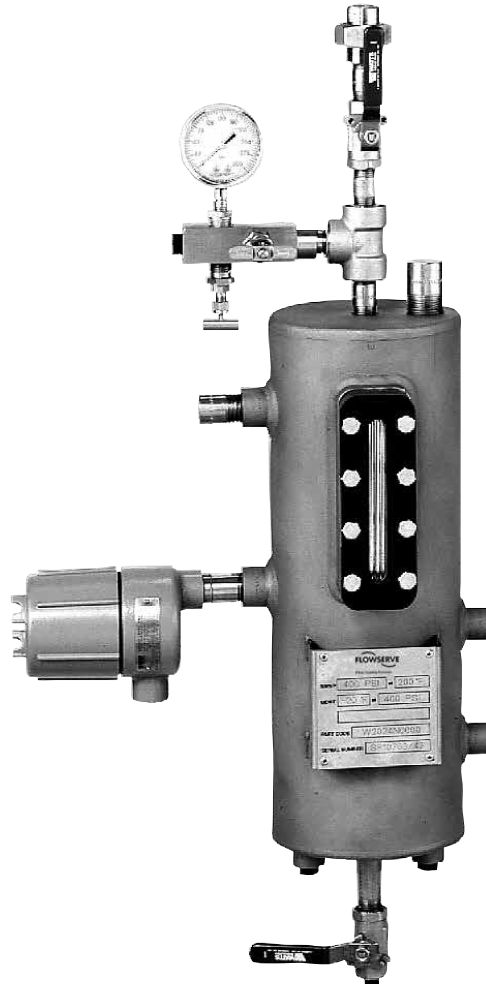



TO REORDER REFER TO

B/M # _____

F.O. _____

FIS124eng REV 09/2018 Printed in USA

**To find your local Flowserve representative
and find out more about Flowserve Corporation,
visit www.flowserve.com**

Flowserve Corporation has established industry leadership in the design and manufacture of its products. When properly selected, this Flowserve product is designed to perform its intended function safely during its useful life. However, the purchaser or user of Flowserve products should be aware that Flowserve products might be used in numerous applications under a wide variety of industrial service conditions. Although Flowserve can provide general guidelines, it cannot provide specific data and warnings for all possible applications. The purchaser/user must therefore assume the ultimate responsibility for the proper sizing and selection, installation, operation, and maintenance of Flowserve products. The purchaser/user should read and understand the Installation Instructions included with the product, and train its employees and contractors in the safe use of Flowserve products in connection with the specific application.

While the information and specifications contained in this literature are believed to be accurate, they are supplied for informative purposes only and should not be considered certified or as a guarantee of satisfactory results by reliance thereon. Nothing contained herein is to be construed as a warranty or guarantee, express or implied, regarding any matter with respect to this product. Because Flowserve is continually improving and upgrading its product design, the specifications, dimensions and information contained herein are subject to change without notice. Should any question arise concerning these provisions, the purchaser/user should contact Flowserve Corporation at any one of its worldwide operations or offices.

© 2017 Flowserve Corporation

USA and Canada

Kalamazoo, Michigan USA

Telephone: 1 269 381 2650

Telefax: 1 269 382 8726

Europe, Middle East, Africa

Etten-Leur, the Netherlands

Telephone: 31 765 028 200

Telefax: 31 765 028 487

Asia Pacific

Singapore

Telephone: 65 6544 6800

Telefax: 65 6214 0541

Latin America

Mexico City

Telephone: 52 55 5567 7170

Telefax: 52 55 5567 4224