

Single Outside Pusher Type Seals

RA, RA-C, RO, RO-TT,
MRA, and Others

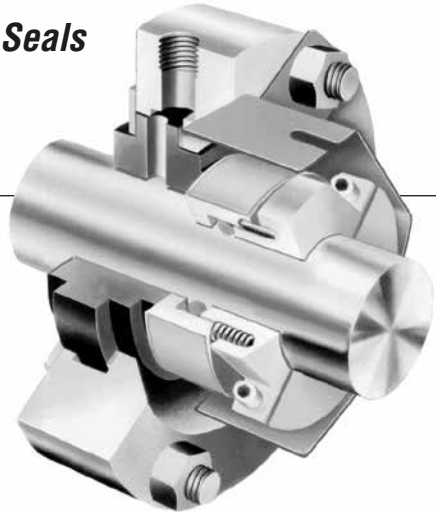

1 Equipment Check

- 1.1 Follow plant safety regulations prior to equipment disassembly:
 - 1.1.1 Wear designated personal safety equipment
 - 1.1.2 Isolate equipment and relieve any pressure in the system
 - 1.1.3 Lock out equipment driver and valves
 - 1.1.4 Consult plant Safety Data Sheet (SDS) files for hazardous material regulations
- 1.2 Disassemble equipment in accordance with the equipment manufacturer's instructions to allow access to seal installation area.
- 1.3 Remove existing sealing arrangement (mechanical seal or otherwise).
Clean seal chamber and shaft thoroughly.
- 1.4 Inspect surfaces under gaskets to ensure they are free from pits or scratches. Break all sharp corners on shaft steps, threads, reliefs, shoulders, key ways, etc. over which gasket(s) must pass and/or seal against.
- 1.5 Check shaft or sleeve OD, seal chamber bore, seal chamber depth, gland pilot, stud diameter, stud bolt pattern and distance to first obstruction to ensure they are dimensionally the same as shown in the seal assembly drawing.
- 1.6 Check seal assembly drawings for any modifications (reworks) to be made to the equipment for mechanical seal installation and act accordingly.
- 1.7 The equipment must be earthed to prevent sparks due to static electricity discharge.

Shaft runout should be checked against the equipment manufacturer's specifications. Generally, should not exceed 0.05 mm (0.002 inch) TIR (Total Indicator Reading) at any point along the shaft for ball or roller type bearings. For sleeve type bearings, refer to manufacturer instructions. If the equipment is not completely dismantled, verify runout near seal location.

The above values apply to shaft speeds in the range from 1000 to 3600 RPM. For values above and below, consult your Flowserve representative. See Figure 1.

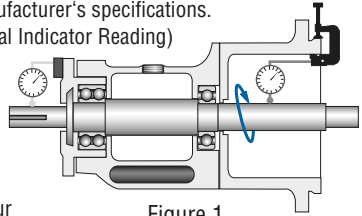

Figure 1

Shaft endplay should not exceed 0.25 mm (0.010 inch) TIR, regardless of thrust bearing type. See Figure 2.

Radial bearing play at seal chamber face should be checked against the equipment manufacturer's specifications. Generally 0.05 - 0.10 mm (0.002 - 0.004 inch) will be applicable for ball or roller type bearings. For sleeve or journal type bearings, values will generally be in the order of 0.10 - 0.15 mm (0.004 - 0.006 inch). If equipment is found outside the general range, contact the equipment manufacturer and your Flowserve representative to verify the equipment's suitability for the seal.

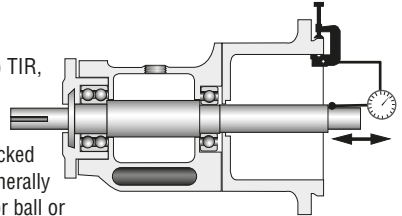

Figure 2

Seal chamber squareness to the shaft centerline should be within 0.0005 mm/mm (0.0005 inch/inch) of seal chamber bore TIR.

Note: make sure that shaft endplay does not affect the reading. Verify the smoothness of the seal chamber face for a good gasket joint. See Figure 3.

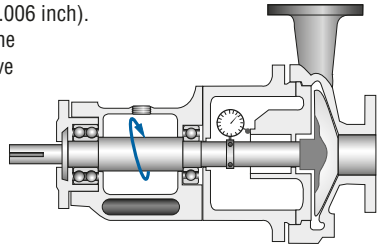

Figure 3

Concentricity of the shaft to the seal chamber bore or gland pilot register should be within 0.025 mm per 25 mm shaft diameter (0.001 inch per 1 inch shaft diameter) to a maximum of 0.125 mm (0.005 inch) TIR. See Figure 4.

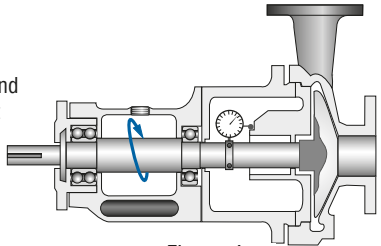
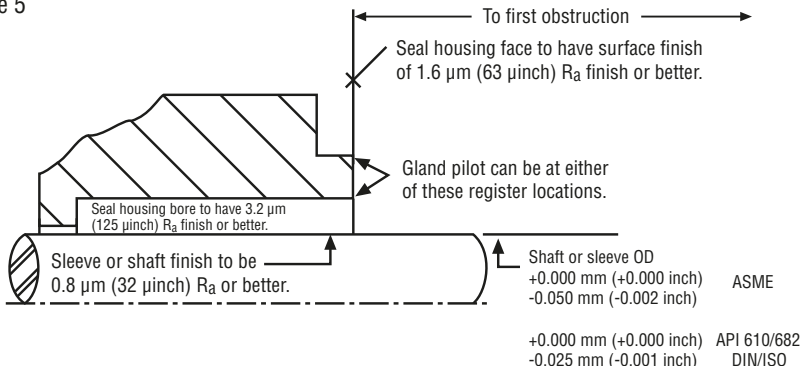

Figure 4

Surface finish requirements

Figure 5



Single Outside Seal Installation

2 Single End Suction Vertical Split Case and Vertical In-Line Pumps (1 box)

- 2.1 **Lubricate the shaft** or sleeve lightly with silicone lubricant provided with the seal before installing any seal parts.
- 2.2 **Install the rotating face gasket** O-ring into the bore of the rotating seal face.
- 2.3 **Engage the rotating assembly** consisting of the spring holder, springs, and seal drive with the rotating face to form the rotating assembly. Be sure any drive pins in the seal drive engage the slots in the rotating face. Handle PTFE U-cup rings and graphite rotating face gaskets with extreme care. U-cup rings must be assembled individually and not pushed on the shaft or sleeve while they are part of the rotating face or rotating assembly. Avoid nicking or pinching either lip on the U-cup rings. Use both U-cup rings, they work together to form an effective seal.
- 2.4 **Install the rotating seal** parts spring holder first onto the shaft or sleeve in the proper sequence with the face of the rotating face facing the impeller. Use a slight twisting motion for any complete rotary unit containing O-ring rotating face gaskets. Place rotating assembly unit as close as possible to the first obstruction, usually the radial bearing.
- 2.5 **Lightly lubricate the O-ring or Duralflex stationary seat gaskets.** Where a stationary face has an O-ring mounting on the shoulder, it is usually better to nest this O-ring in the gland cavity before installing the face. Other stationary face mountings can be assembled on the stationary face shoulder.
- 2.6 **Press the stationary face into the gland** with the sealing face orientated toward the outboard side of the gland, facing the rotating seal face. Use hand pressure only.
- 2.7 **Position the gland** over the shaft or sleeve with the stationary sealing face orientated toward the rotating face sealing face. Place the gland as close to the rotating assembly as possible. Do not bump the stationary face against the shaft as it may chip, crack, or break.
- 2.8 **Install the pump back-plate and assemble the pump. Position the gland** so the gland or stationary face pilot is properly engaged and **tighten the gland stud nuts** up evenly, cross staggering the adjustment of the nuts. The gland nuts should be torqued to a maximum of 13 N-m (10 ft-lbs). Excessive gland nut pressure can result in distortion of the insert. **Adjust the bearings, coupling, and impeller** so that the shaft is in its operating axial position. Any subsequent axial adjustment of the shaft requires resetting of the seal rotary unit.
- 2.9 **Wipe the seal faces clean** with alcohol. Seal faces should not be lubricated but should be left clean and dry.
- 2.10 **Position the rotating assembly** so that the seal faces are in contact and position the spring holder so that the spring gap (or bellows rotary unit length) is that given on the assembly drawing. The spring gap dimension is also stamped on the spring holder. **Tighten the set screws** firmly and evenly.
- 2.11 **See paragraph 4, Operational Recommendations** before starting pump.

3 Double Suction and Multistage Horizontal Split Case Pumps (2 boxes)

- 3.1 **Lubricate the shaft** or sleeve lightly with silicone lubricant provided with the seal before installing any seal parts.
- 3.2 **Lightly lubricate the O-ring or Duralflex stationary seat gaskets.** Where a stationary face has an O-ring mounting on the shoulder, it is usually better to nest this O-ring in the gland cavity before installing the face. Other stationary face seat gaskets can be assembled on the stationary face shoulder.
- 3.3 **Press the stationary face into the gland** with the sealing face orientated toward the outboard side of the gland, facing the rotating face. Use hand pressure only.
- 3.4 **Position the gland** over the shaft or sleeve so that the gland or stationary face pilot is properly engaged and the stationary face sealing face is facing out. Do not bump the stationary face against the shaft as it may chip, crack, or break. **Tighten the gland stud nuts** evenly in a diagonal sequence. Do not over tighten the gland nuts. Excessive gland nut pressure can distort the stationary face.
- 3.5 **Adjust the bearings, coupling, and impeller** so that the shaft is in its operating axial position. Any subsequent axial adjustment of the shaft requires resetting of the seal rotating assembly.
- 3.6 **Install the rotating face gasket** O-ring into the bore of the rotating face.



TO REORDER REFER TO

B/M # _____

F.O. _____

- 3.7 **Engage the rotating assembly** consisting of the spring holder, springs, and seal drive with the rotating face to form the rotating assembly. Be sure any drive pins in the seal drive ring engage the slots in the rotating face. This is the complete rotating assembly. Handle PTFE U-cup rings and **Durafite** rotating face gaskets with extreme care, PTFE U-cup rings must be assembled individually and not pushed on the shaft or sleeve while they are part of the rotating face rotating assembly. Avoid nicking or pinching either lip of the U-cup ring. Use both U-cup rings, they work together to form an effective seal.
- 3.8 **Install the rotating seal component** parts on the shaft or sleeve in the proper sequence with the face of the rotating face facing the sealing face that is in the gland. Use a slight twisting motion for any complete rotary unit containing O-ring rotating face gasket.
- 3.9 **Wipe the seal faces clean** with alcohol. Seal faces should not be lubricated but be left clean and dry.
- 3.10 **Position the rotating assembly** so that the seal faces are in contact and position the spring holder so that the spring gap (or bellows rotary unit length) is that shown on the assembly drawing. **Tighten the set screws** firmly and evenly.
- 3.11 **See paragraph 4, Operational Recommendations** before starting pump.

Note: Seal designs incorporating a **bushing style stationary face** do not include a gland. Lubricate the stuffing box bore and the O-rings with the silicone lubricant provided with the seal. Hand press the bushing into the bore of the stuffing box. Follow the above procedures for installation of the rotating seal components.

4 Operational Recommendations

- 4.1 **Do not start up the equipment dry.** Vent air from the casing of the pump and the stuffing box before start-up. Circulate clean product or a clean fluid from an external source through the stuffing box whenever the equipment is in operation, Plan 11 or 32.
- 4.2 If the seal runs hot, check for proper seal setting, seal housing dimensions, and check the bypass or flush line for obstructions. Do not allow the equipment to run for any extended time if the seal gets hot or squeals. For special problems encountered during installation, contact your nearest Flowserve Sales and Service Representative or Authorized Distributor.

5 Repair

This product is a precision sealing device. The design and dimension tolerances are critical to seal performance. Only parts supplied by Flowserve should be used to repair a seal. To order replacement parts, refer to the part code and B/M number. A spare backup seal should be stocked to reduce repair time.

When seals are returned to Flowserve for repair, **decontaminate the seal assembly** and include an order marked **"Repair or Replace."** A **signed certificate of decontamination** must be attached. A **Safety Data Sheet (SDS) must be enclosed** for any product that came in contact with the seal. The seal assembly will be inspected and, if repairable, it will be rebuilt, tested, and returned.

FIS116eng REV 09/2018 Printed in USA

© 2015 Flowserve Corporation

To find your local Flowserve representative and find out more about Flowserve Corporation, visit www.flowserve.com

Flowserve Corporation has established industry leadership in the design and manufacture of its products. When properly selected, this Flowserve product is designed to perform its intended function safely during its useful life. However, the purchaser or user of Flowserve products should be aware that Flowserve products might be used in numerous applications under a wide variety of industrial service conditions. Although Flowserve can provide general guidelines, it cannot provide specific data and warnings for all possible applications. The purchaser/user must therefore assume the ultimate responsibility for the proper sizing and selection, installation, operation, and maintenance of Flowserve products. The purchaser/user should read and understand the installation instructions included with the product, and train its employees and contractors in the safe use of Flowserve products in connection with the specific application.

While the information and specifications contained in this literature are believed to be accurate, they are supplied for informative purposes only and should not be considered certified or as a guarantee of satisfactory results by reliance thereon. Nothing contained herein is to be construed as a warranty or guarantee, express or implied, regarding any matter with respect to this product. Because Flowserve is continually improving and upgrading its product design, the specifications, dimensions and information contained herein are subject to change without notice. Should any question arise concerning these provisions, the purchaser/user should contact Flowserve Corporation at any one of its worldwide operations or offices.

USA and Canada

Kalamazoo, Michigan USA
Telephone: 1 269 381 2650
Telefax: 1 269 382 8726

Asia Pacific

Singapore
Telephone: 65 6544 6800
Telefax: 65 6214 0541

Europe, Middle East, Africa

Etten-Leur, the Netherlands
Telephone: 31 765 028 200
Telefax: 31 765 028 487

Latin America

Mexico City
Telephone: 52 55 5567 7170
Telefax: 52 55 5567 4224