

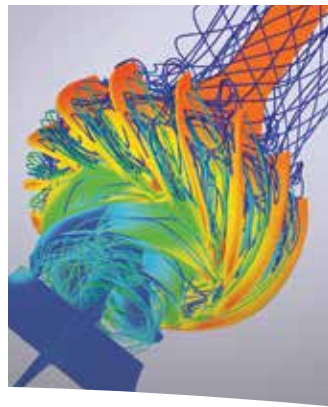

***Type M  
Hard Metal Abrasive Slurry Pump***



***Experience In Motion***



## ***Pump Supplier to the World***

*Flowserve is the driving force in the global industrial pump marketplace. No other pump company in the world has the depth or breadth of expertise in the successful application of pre-engineered, engineered, and special purpose pumps and systems.*

### ***Life Cycle Cost Solutions***

Flowserve provides pumping solutions that permit customers to reduce total life cycle costs and improve productivity, profitability and pumping system reliability.

### ***Market-Focused Customer Support***

Product and industry specialists develop effective proposals and solutions directed toward market and customer preferences. They offer technical advice and assistance throughout each stage of the product life cycle, beginning with the initial inquiry.

### ***Broad Product Lines***

Flowserve offers a wide range of complementary pump types, from pre-engineered process pumps to highly engineered and special purpose pumps and systems. Pumps are built to recognized global standards and customer specifications.

Pump designs include:

- Single-stage process
- Between bearings single-stage
- Between bearings multistage
- Vertical
- Submersible motor
- Positive displacement
- Nuclear
- Specialty

### ***Product Brands of Distinction***

*ACEC™ Centrifugal Pumps*

*Aldrich™ Pumps*

*Byron Jackson® Pumps*

*Calder™ Energy Recovery Devices*

*Cameron™ Pumps*

*Durco® Process Pumps*

*Flowserve® Pumps*

*IDP® Pumps*

*Lawrence Pumps®*

*Niigata Worthington™ Pumps*

*Pacific® Pumps*

*Pleuger® Pumps*

*Scienco™ Pumps*

*Sier-Bath® Rotary Pumps*

*TKL™ Pumps*

*United Centrifugal® Pumps*

*Western Land Roller™ Irrigation Pumps*

*Wilson-Snyder® Pumps*

*Worthington® Pumps*

*Worthington Simpson™ Pumps*

**Type M**

**Hard Metal Abrasive Slurry Pump**



**Complementary Pumps**

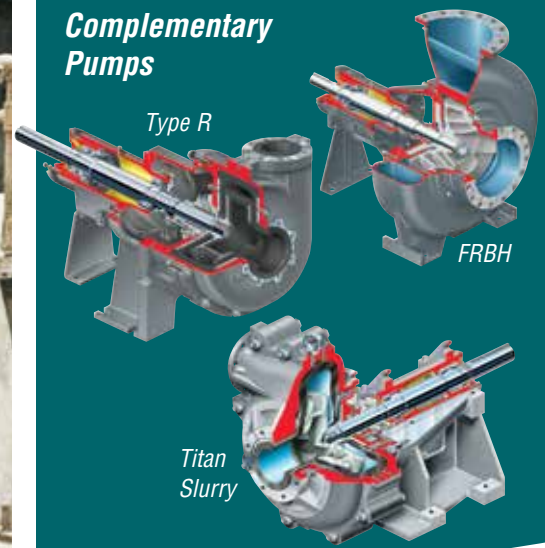

**Engineered to Handle the Toughest Duties**

*The type M hard metal slurry pump reflects a century-old commitment to combating the harshest applications in mining, mineral processing, metal production and pollution abatement, just to name a few. The pump's hydraulic design, materials of construction and configuration versatility provide the necessary durability and site-specific fit required to handle the toughest duties.*

With its corrosion- and abrasion-resistant high chrome iron casing, the M pump complements the Flowserve type R rubber-lined slurry pump. Together, they form an extended product range that comprises 34 liquid ends and includes both horizontal and vertical designs. This versatility allows pumps to be well configured to site requirements and sized near their peak efficiency.

**Typical Applications**

- Mining and mineral processing
- Primary metals processing
- Sand and gravel
- Flue gas wet scrubbing
- Synthetic fuels
- Ethanol production
- Vertical wet-pit sump
- Oil sands and froth processing

**Significant Benefits**

- Versatility
  - Several configurations
  - Choice of materials
  - Multiple impeller designs
  - Optional inducer
  - Parts interchangeability
  - Several shaft sealing options
- Reliability
  - Extra thick wear allowances
  - Oversized shaft and bearings
  - Stuffing box protector plate
- Ease of maintenance
  - Open stuffing box access
  - Cartridge style bearing frame
- Reduced operating costs via optimal hydraulic selection

**Complementary Pumps Designs**

Flowserve can also provide the following pumps:

- Type R rubber-lined slurry pump
- RJ and RJC rubber-lined, vertical slurry pumps
- Titan™ Slurry heavy-duty, dual case, lined slurry pump
- Terra-Titan lined sump pump
- FRBH heavy-duty paper stock process pump
- LC chemical slurry pump

**Type M**  
**Hard Metal**  
**Abrasive**  
**Slurry Pump**

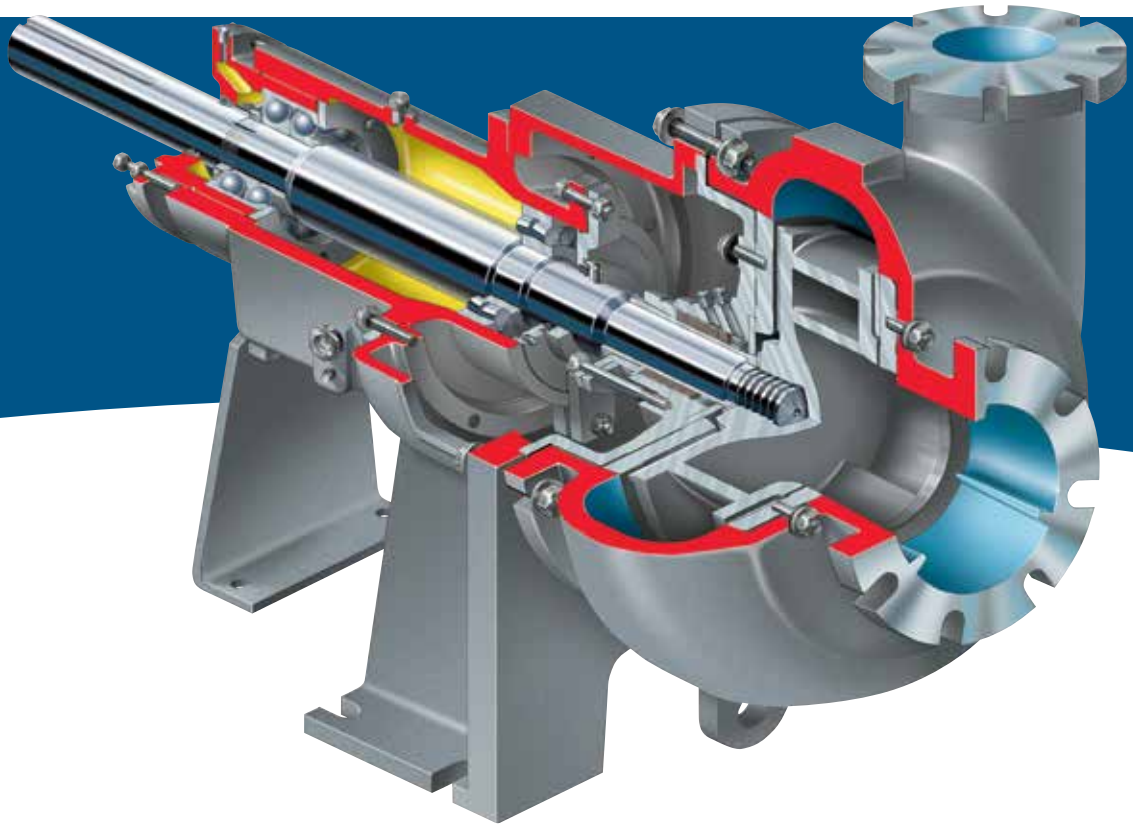

*The Flowserve type M hard metal slurry pump is a horizontal, single-stage, end suction design with a tangential discharge nozzle. Fitted with a hard metal liquid end, the M pump is engineered to handle high concentrations of coarse, abrasive solids in suspension.*

**Operating Parameters**

- Flows to 10 000 m<sup>3</sup>/h (44 000 gpm)
- Heads to 90 m (300 ft)
- Pressures to 10 bar (150 psi); 50 bar (725 psi) on high-pressure models
- Temperatures to 120°C (250°F)
- Solids from 2% to 70% by weight; medium to large sized, sharp particles
- Specific gravities from 1.0 to 2.7

**Features and Benefits**

**High Chrome Iron Hard Metal Casing** is free from cavities and obstructions that are susceptible to wear. Meets ASTM A532, Class 3, Type A, Level 1.

**Hard Metal Wear Plates** on front and rear of the casing are secured externally by heavy-duty studs. Close clearance machined fits eliminate rings and simplify pump assembly.

**Closed Impeller** with external pumping vanes on front and rear shroud reduces stuffing box pressure and suction recirculation while sweeping away solids.

**Anti Pre-rotation Vanes** reduce suction pipe swirl and extend impeller life.

**Slotted Flanges** to 300 mm (12 in) diameter are compatible with ASME (ANSI) Class 150 flat face flanges, and ISO PN16 flanges without adapters.

**Heavy-duty Bearing Frame** is generously sized to handle belt loads and can be removed easily in one piece for maintenance.

**Three-point External End-clearance Adjustment** restores impeller front clearance to optimize efficiency, without using shims.

**Hook Sleeve** and replaceable metallic impeller spacer have gasket seals to isolate shaft and impeller threads from slurry and ease impeller removal. Locking collar and straight sleeve are used for the largest sizes.

**Stuffing Box** access is from side openings on smaller units, which permits maintenance when motors are mounted above the pumps. For units with motors too large for overhead mounting, the access is from the large top opening.

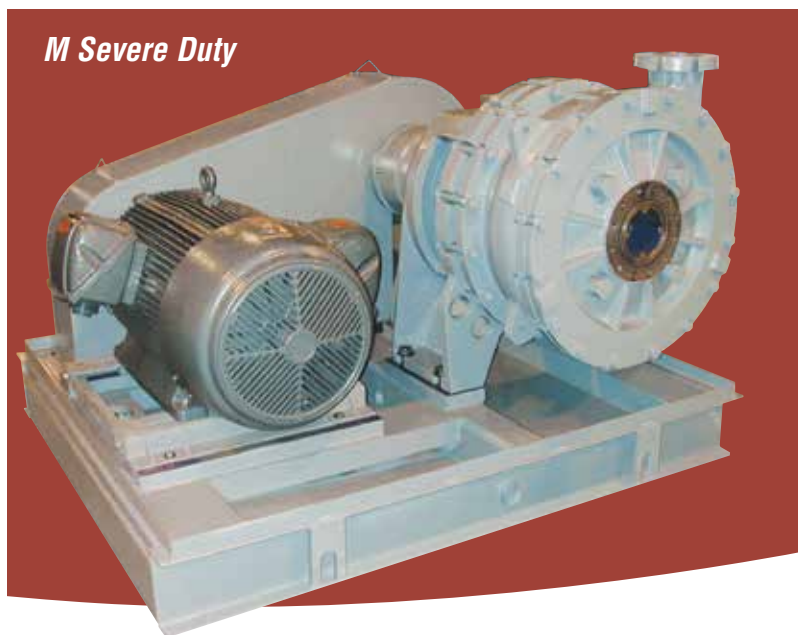
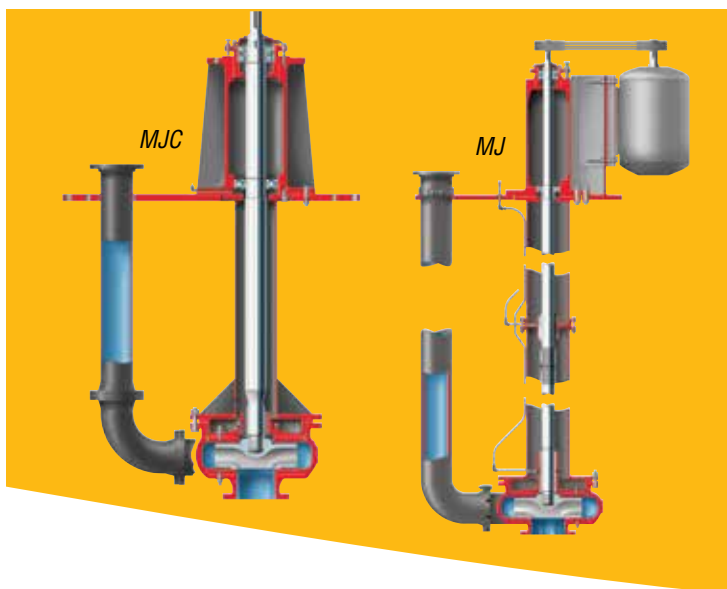

### Vertical Hard Metal Slurry Pumps

To suit site requirements, the M pump is available in two vertical configurations — the MJ water-lubricated lineshaft and MJC cantilever designs. Designed to use horizontal liquid end parts, the MJ and MJC are suitable for wet-pit applications and can be directly coupled or V-belt driven.

#### MJC Cantilever Design

A true stiff-shaft cantilever design without bottom bearings, the MJC pump is particularly well suited for applications in which flushing liquids are not available or cannot be tolerated.

#### MJ Lineshaft Design

A vertical pump with bottom bearings, the line bearings and any spider bearings are submerged in the sump. Thrust bearings are mounted above the sump. The lower bearing housing is fitted with a rubber or graphite fluted bearing, which is contained in a rigid stainless steel shell and lubricated from an external clear liquid source.

#### MJ and MJC Operating Parameters

- Flows to 1350 m<sup>3</sup>/h (6000 gpm)
- Heads to 30 m (100 ft)

### Interchangeability Among Designs

Interchangeability among the M pump's various configurations translates into reduced inventory requirements and reduced operating costs. This benefit also extends to the FlowsERVE type R pump, a rubber-lined slurry pump which shares many components with the M pump. Facilitating changes in service or operating conditions, the liquid end of these pumps can be converted to or from the hard metal design.

### M Severe Duty

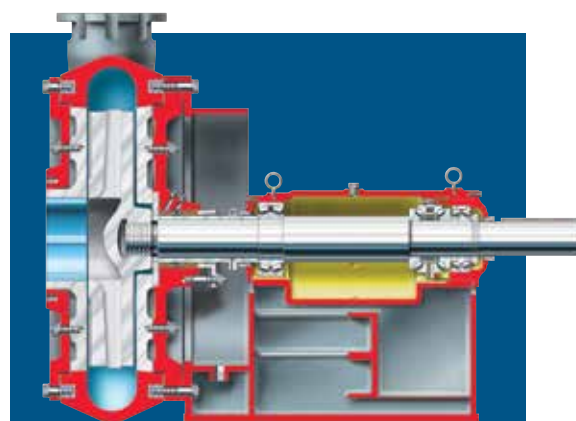

### Severe Duty Design

The M Severe Duty pump is for aggressive applications that require higher heads in a single-stage design, or for high concentrations of coarse solids. To ensure long-lasting performance and reliability, the design features:

- Thicker wear parts
- Full diameter wear plates
- Low specific speeds
- Low NPSHR
- Large diameter impeller
- Front opening casing to facilitate replacement of critical wear parts

#### Typical Applications

- Primary cyclone feed
- Filter feed
- Tailings
- Paste slurries
- Heavy media separation
- Pipelines

**Options and Technical Data**

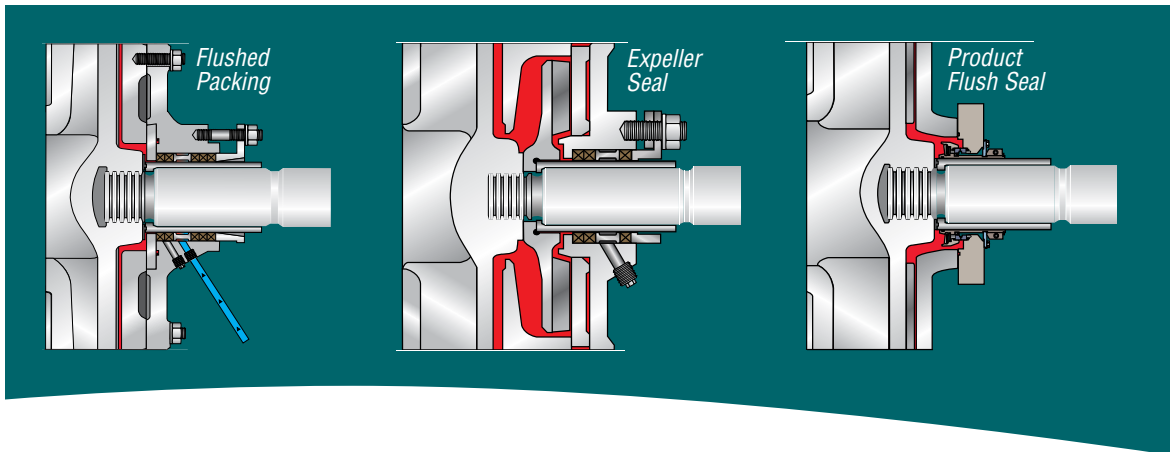

**Numerous Shaft Sealing Options**

**Flushed Packing or Mechanical Seal**

- Cast iron or stainless
- Replaceable protector plate prevents wear on stuffing box and restricts solids from entering
- High flow flush option — Lantern ring followed by five rings of packing (L5)
- Standard flush option — Two rings of packing, the lantern ring and three more rings of packing (2L3)

**Expeller Seal**

- Eliminates external flush and product dilution
- Dry running
- Grease-lubricated packing forms static seal

**Product Flush Slurry Seals**

- Stuffing box and gland side wear plate replaced with hard metal seal housing
- Seal located behind impeller and fitted in tapered housing for optimum product circulation

**High-Pressure Modifications**

High-pressure modifications are available for series pumping and dewatering applications. Working pressures to 50 bar (725 psi). May include seven-ring stuffing box, high tensile yield materials and casing ribs.



**Vortex Impeller**

An optional vortex impeller with a semi-open, straight vane design is available for applications containing large or stringy solids. It is also helpful on services containing entrained air.

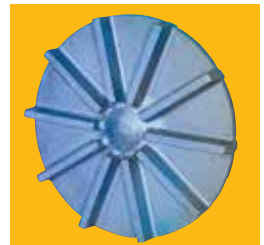

**Type M Range Chart**

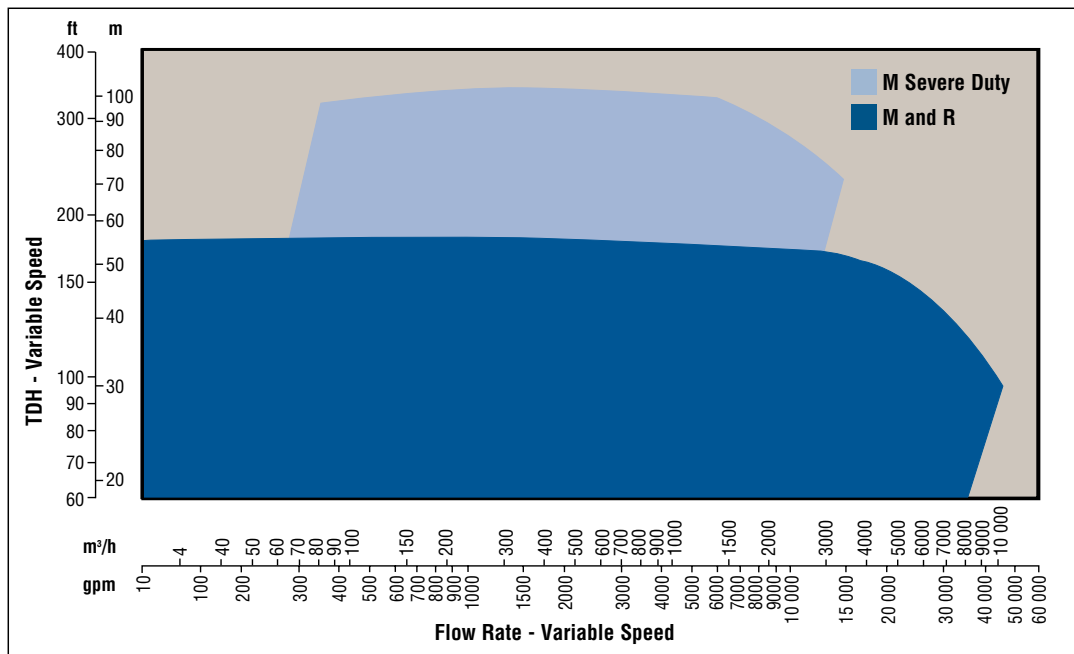

Global Service  
and Technical  
Support



## Life Cycle Cost Solutions

Typically, 90% of the total life cycle cost (LCC) of a pumping system is accumulated after the equipment is purchased and installed. Flowserve has developed a comprehensive suite of solutions aimed at providing customers with unprecedented value and cost savings throughout the life span of the pumping system. These solutions account for every facet of life cycle cost, including:

### Capital Expenses

- Initial purchase
- Installation

### Operating Expenses

- Energy consumption
- Maintenance
- Production losses
- Environmental
- Inventory
- Operating
- Removal

### Innovative Life Cycle Cost Solutions

- New Pump Selection
- Turnkey Engineering and Field Service
- Energy Management
- Pump Availability
- Proactive Maintenance
- Inventory Management

### Typical Pump Life Cycle Costs<sup>1</sup>

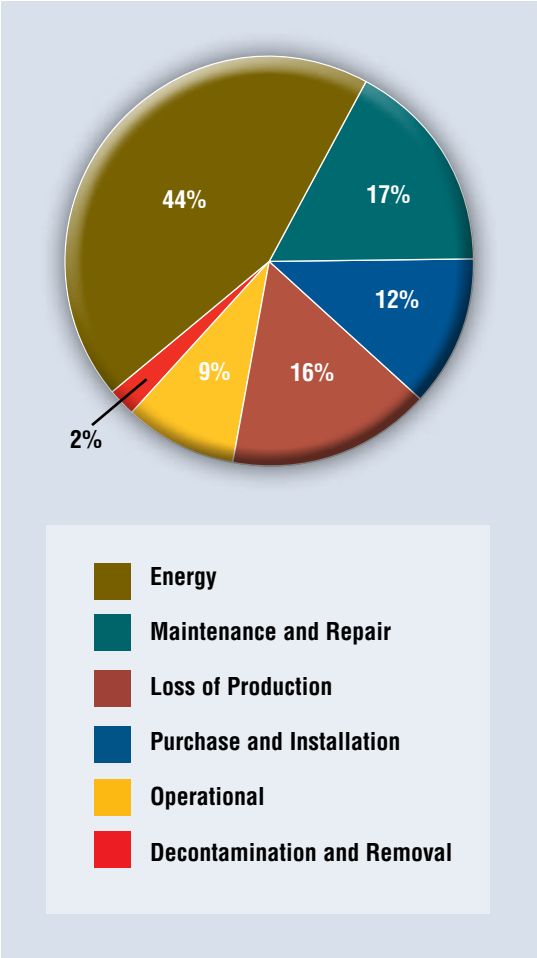

<sup>1</sup> While exact values may differ, these percentages are consistent with those published by leading pump manufacturers and end users, as well as industry associations and government agencies worldwide.

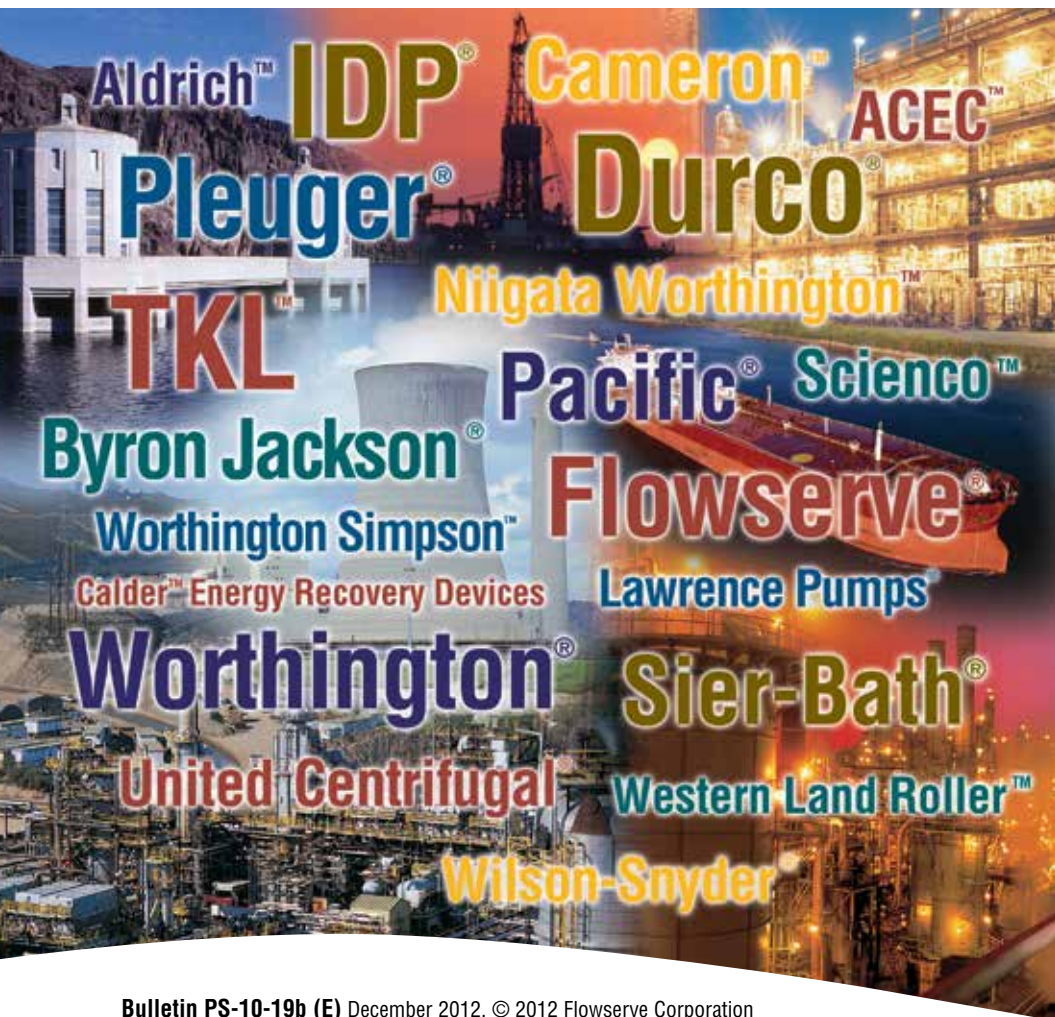

**USA and Canada**  
Flowserve Corporation  
5215 North O'Connor Blvd.  
Suite 2300  
Irving, Texas 75039-5421 USA  
Telephone: +1 937 890 5839

**Europe, Middle East, Africa**  
Flowserve Corporation  
Parallelweg 13  
4878 AH Etten-Leur  
The Netherlands  
Telephone: +31 76 502 8100

**Latin America**  
Flowserve Corporation  
Martín Rodríguez 4460  
B1644CGN-Victoria-San Fernando  
Buenos Aires, Argentina  
Telephone: +54 11 4006 8700  
Telefax: +54 11 4714 1610

**Asia Pacific**  
Flowserve Pte. Ltd.  
10 Tuas Loop  
Singapore 637345  
Telephone: +65 6771 0600  
Telefax: +65 6862 2329

Bulletin PS-10-19b (E) December 2012. © 2012 Flowserve Corporation

**To find your local Flowserve representative:**

For more information about Flowserve Corporation, visit [www.flowserve.com](http://www.flowserve.com) or call +1 937 890 5839.