

## R5 Actuator

### R5 Scotch-Yoke Actuator

The R5 scotch-yoke actuator is an extension to the R-series pneumatic scotch-yoke actuator. The R5 actuator will produce up to 500,000 in.-lb. double acting torque and 225,000 in.-lb. spring end torque.

#### Installation to Valve

1. All actuators are factory lubricated for life, but still should be protected from the elements and stored indoors until ready for use. The ports of the actuator are plugged as supplied from the factory. If actuators are stored for a long period of time prior to installation, the actuators should be stroked every 3 months to prevent the seals from taking set. See bulletin B00129 for long term storage instructions.
2. Prior to assembly, manually open and close valve to ensure freeness of operation. Be sure valve and Automax actuator rotate in the same direction and are in the same position (i.e., valve closed, actuator closed).
3. Check the mounting surfaces, the stem adaptor, and the bracket to assure proper fit. Secure the valve in the closed position with the stem vertical. Bolt the bracket to the valve and place the stem adaptor on the valve stem. Position the actuator over the valve and lower to engage the stem adaptor to the actuator output bore. Continue to lower until the actuator seats on the bracket mounting surface. In order to align the bolt holes, it may be necessary to turn or stroke the actuator a few degrees and/or adjust the actuator travel stops. Bolt the actuator to the bracket.
4. Adjust the travel stop bolts of the actuator for the proper open and closed valve positions, per valve manufacturer's recommendations. Pneumatically stroke the actuator several times to assure proper operation. The stem adaptor should not bind during operation. If the actuator is equipped with an UltraSwitch or other accessories, adjust them at this time.
5. To prolong actuator life use only clean, dry plant air. Lubricated air is not required, however it is recommended particularly for high cycle applications. Do not use lubricated air with positioners.

### Travel Stop Adjustments

All actuated valves require accurate travel-stop adjustments at both ends of the stroke to obtain optimum performance and valve seat life. The accumulation of tolerances in the adaption of actuators to valves is such that there must be a range of adjustments for both ends of the stroke to achieve optimum performance.

The R5 actuator has travel stop adjustments in both the clockwise and counter-clockwise directions. The 12 degree over-travel feature provides adjustments from -6 to +96 degrees.

### Field Conversion from Fail CW to Fail CCW (for Spring Return Actuators)

The R5 spring return actuator can be converted from fail CW to fail CCW easily. Simply turn actuator over and mount to valve. This is easily accomplished due to identical valve and accessory mounting pattern machined in the body and cover. Follow steps below:

1. Disconnect all air and electrical supplies from actuator.
2. Remove any accessories from top actuator mounting surface.
3. If actuator is mounted to valve dismount actuator from valve.
4. Remove valve mounting bracket from bottom actuator mounting surface.
5. Turn actuator over so that the body cover is now facing down.
6. Install actuator to valve as described above, using valve mounting pattern on body cover. (Be sure actuator and valve are in same position)
7. Reinstall any accessories that were removed from actuator.
8. Check actuator for proper operation.

## Maintenance Instructions

### Disassembly Instructions

1. Disconnect all air and electrical supplies from actuator.
2. Remove all accessories from actuator and dismount from valve.

### Spring Group

*NOTE: PERSONAL INJURY may result if Step 2 is attempted before Step 1 is completed.*

1. Apply air pressure to port DA2 to release spring pressure from the Stop Bolt (10). Remove both Stop Bolts (10) and release air pressure. This will relieve the majority of the spring preload.
2. The Spring Cartridge (47) is welded into an integral component and cannot be disassembled. To remove from actuator, remove Spring Cartridge Adapter Nuts (34) and Lockwashers (35). At this point, all spring forces are contained within the welded cartridge and the Spring Cartridge can be removed from the center body.
3. Before reassembling Spring Cartridge to body, make sure stud threads are clean of any dirt, shavings, or other debris. Clean threads with rag and solvent if required, and lubricate threads with an anti-sieze compound.

*Note: Support the Spring Cartridge (47) during removal so as not to damage the Piston Rod (7).*

### Pressure Group

1. Check that all air is exhausted from the cylinder.
2. Remove the Tie Rod Nuts (37), Tie Rods (36), and the Endcap (30).
3. Slide the Cylinder (32) over and off the Piston (31), being careful not to scratch or dent the honed and chrome plated surface of the cylinder.
4. Remove the Piston Bolt (38) and Piston Bolt Lockwasher (39). Remove the Piston (31) and Piston Face Seal (44).
5. Remove the Adaptor Stud Nuts (34) and Lockwashers (35) and carefully slide the Adapter (29) over the Piston Rod (7).

### Housing (Body Group)

*NOTE: Spring Cartridge must be removed and air pressure must be removed from cylinders before the cover can be taken off the body.*

1. Remove cylinder Piston Rod (7) and spring side Piston Rod (7) from Yoke Block (4).

2. Remove Body Cover Bolts (18) and Lockwasher (19). Remove cover by turning cover jackscrews (40) until cover is separated enough to pry apart.
3. Remove Yoke Pin Rollers (5), Yoke Pin (6), and Yoke Block (4).
4. Lift Yoke (3) out of body bore.
5. Remove Yoke Seals (23) and Yoke Bushing (21).

### Reassembly Procedures

1. Inspect all parts for wear and replace any worn parts as needed. Normally, all seals and gaskets should be replaced when reassembling an actuator.
2. Clean and grease all components with a multipurpose "polymer" fortified grease such as DuBois Chemical MPG-2. For low temperature units, use Lubriplate Low Temperature grease or equivalent.
3. Reverse the disassembly procedures to reassemble. Use the proper torque from the torque chart on the Tie Rod Locknuts (37), the Adapter Nuts (34), the Spring Cartridge Adapter Nuts (34), and the Piston Bolt (38). These threads should be lubricated with Locktite Threadlocker 242 or equivalent prior to assembly.
4. See parts and materials drawing which depicts all required spare parts.

Test the actuator for smooth operation and air leakage at service pressure before re-installing.

## Bolt Torques

	<u>Bolt Size</u>	<u>Torque Range</u>
<b>Piston Bolt (38)</b> (SAEGr.8 Bolt)	1 1/4"-7 UNC	1014-1116 ft.lb.
<b>Adapter Studs (34)</b> (ASTM A1 93 Gr. B7)	7/8"-9 UNC	364-403 ft.lb.
<b>Tie Rods (36)</b> (ASTM A311 Stressproof)	7/8"-9 UNC	336-371 ft.lb.
	1"-8 UNC	503-556 ft.lb.
	1 1/4"-7 UNC	503-556 ft.lb.

Note:

- 14"-16" cylinders have 7/8"-9 Tie Rods
- 18"-22" cylinders have 1"-8 Tie Rods
- 24" cylinders have 1 1/4"-7 Tie Rods

## How To Order:

R5	22	14	SR1	H	V
(1)	(2)	(3)	(4)	(5)	(6)



Flowserve Corporation  
Flow Control Division  
www.flowserve.com

765 South 100 East  
Provo, Utah 84606  
Phone: 801 373 3028

1978 Foreman Dr.  
Cookeville, TN 38501  
Phone: 931 432 4021

- (1) R5 - R5 Model
- (2) Cylinder Size
- (3) Optional Dual Cylinder Size (blank if not present)
  - 14 - 14" Cylinder
  - 16 - 16" Cylinder
  - 18 - 18" Cylinder
  - 20 - 20" Cylinder
  - 22 - 22" Cylinder
  - 24 - 24" Cylinder

Note: larger cylinder is listed first, if present. See Torque Charts for available combinations.

- (4) Fail-Safe Option
  - DA - Double Acting
  - SRxx Spring Return, where 'xx' denotes air pressure at balanced torque
- (5) Override Option
  - Blank - none
  - H - Hydraulic Override
- (6) Temperature Option
  - Blank - standard -20° to 180°F (nitrile seals)

- (7) Trim Option
  - Blank - standard materials, polyurethane paint
  - E - standard materials, white epoxy coating
  - G - standard materials, gray epoxy coating
  - M - marine trim

Example: R5 with dual 18" cylinders, double acting, with epoxy paint is **R51818DAE**.

- Seal Kits:
- Standard - R(Actuator Base Model)SKB
  - High Temp - R(Actuator Base Model)SKV
  - Low Temp - R(Actuator Base Model)SKL

Example: High Temp. viton seal kit for R522145R80 is **R52214SKV**.

## Actuator Weights and Volumes

Actuator Model	Volume (in <sup>3</sup> )	Weights (lb.)				
		DA	SR40	SR60	SR80	SR100
R514	3,233	932	N/A	N/A	N/A	N/A
R51414	6,466	1,199	N/A	N/A	N/A	N/A
R516	4,222	1,066	N/A	N/A	N/A	2,040
R51614	7,455	1,333	N/A	N/A	N/A	N/A
R51616	8,444	1,467	N/A	N/A	N/A	N/A
R518	5,344	1,180	1,938	1,992	2,153	2,260
R51816	9,566	1,581	N/A	N/A	N/A	N/A
R51818	10,688	1,695	N/A	N/A	N/A	N/A
R520	6,597	1,297	2,035	2,253	2,378	2,559
R52020	13,194	1,929	N/A	N/A	N/A	N/A
R522	7,983	1,463	2,276	2,437	2,725	2,888
R52214	11,216	N/A	2,704	2,992	3,274	3,437
R524	9,500	1,730	2,686	2,811	3,155	3,274
R52416	13,722	N/A	3,212	3,556	3,838	N/A

V - high temperature 0° TO 300°F (viton)  
L - Low Temperature -55° to 180°F (nitrile)

Flowserve Corporation  
Flow Control Division  
www.flowserve.com

765 South 100 East  
Provo, Utah 84606  
Phone: 801 373 3028

1978 Foreman Dr.  
Cookeville, TN 38501  
Phone: 931 432 4021

### Parts and Materials

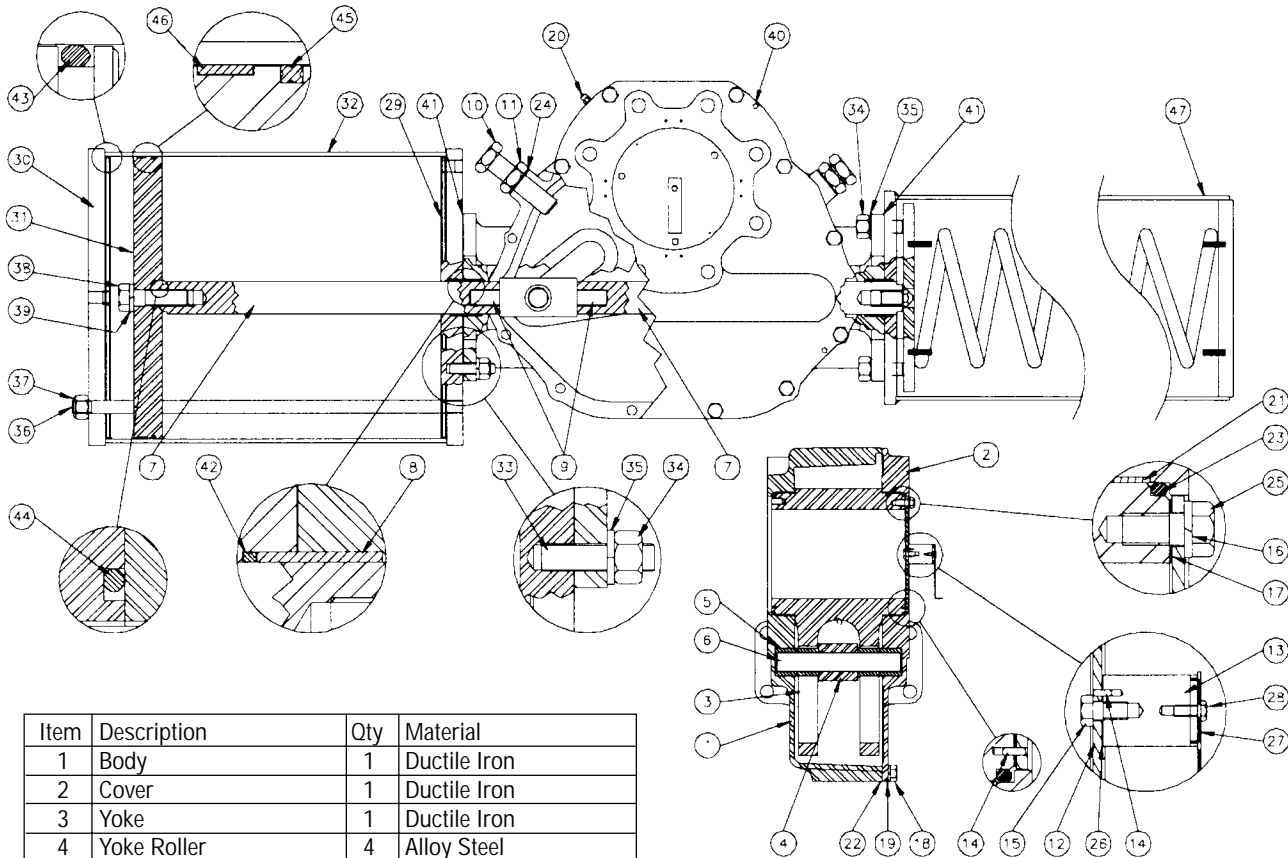

Item	Description	Qty	Material
1	Body	1	Ductile Iron
2	Cover	1	Ductile Iron
3	Yoke	1	Ductile Iron
4	Yoke Roller	4	Alloy Steel
6	Yoke Pin	1	Carbon Steel
7	Piston Rod	1	Carbon Steel
8	Rod Bushing	1	Bronze
9	Rod Stud	1	Alloy Steel
10	Stop Bolt	2	Alloy Steel
11	Stop Bolt Locknut	2	Carbon Steel/Zn
12	Indicator Plate	1	Carbon Steel
13	Accessory Coupler	1	Carbon Steel
14	Roll Pin	3	Alloy Steel
15	Coupler Bolt	1	Carbon Steel
16	Indicator Plate Bolt	3	Carbon Steel
17	Lockwasher	3	Carbon Steel/Zn
18	Body Cover Bolt	12	Carbon Steel
19	Lockwasher	12	Carbon Steel/Zn
20	Pressure Relief Valve	1	Brass/Nitrile
21	Yoke Bushing	2	Steel/Teflon/Bronze
22*	Cover Gasket	1	Gasket Material
23*	Yoke Seal	2	Nitrile
24*	Stop Bolt Thread Seal	2	Steel/N Nitrile
25*	Indicator Plate Gasket	1	Gasket Material
26*	Coupler Gasket	1	Gasket Material
27	Indicator	1	Carbon Steel

Item	Description	Qty	Material
28	Indicator Bolt	1	Carbon Steel
29	Adapter	1	Carbon Steel
30	Endcap	1	Carbon Steel
31	Piston	1	Carbon Steel
32	Cylinder	1	Carbon Steel/Chrome
33	Adapter Stud	8	Carbon Steel
34	Adapter Nut	8	Carbon Steel
35	Lockwasher	8	Carbon Steel/Zn
36	Tie Rod	4	Carbon Steel
37	Tie Rod Nut	4	Carbon Steel
38	Piston Bolt	1	Carbon Steel
39	Lockwasher	1	Carbon Steel/Zn
40*	Adapter Gasket	1	Gasket Material
41	Piston Rod Seal	1	Nitrile
42*	Adapter Bolt Seal	8	Nitrile
43*	Endcap Seal	2	Nitrile
44*	Piston Bolt Seal	1	Nitrile
45*	Piston Seal	1	Nitrile
46	Piston Wear Band	1	Teflon
47	Spring Cartridge	1	Carbon/Alloy Steel

\*Recommended spare parts