

SX-Series Stainless Steel Actuator

Introduction:

The Automax SX-Series stainless steel actuators are a corrosion resistant rack and pinion actuator suitable for use in corrosive environments. The SX Series stainless steel actuator is well suited for automating butterfly, ball, and plug valves in harsh, corrosive environments. All external components of the actuator are 300 series stainless steel which enables the actuator to withstand corrosive environments typically found in chemical and petrochemical plants, as well as other locations. Optional APS2 or stainless steel pistons and springs extend the corrosion protection to internal components. The SX-Series stainless steel actuator is ideal for the most demanding applications, including chemical processing, pulp and paper, marine and offshore, food and beverage, and nuclear applications.

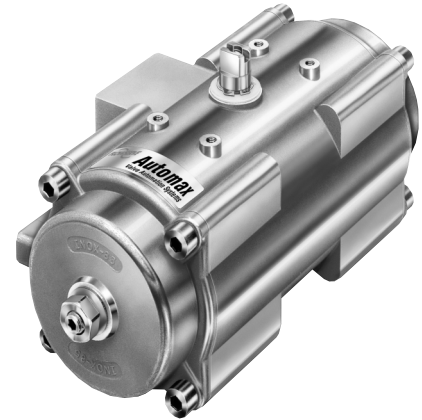

Features:

- 1. NAMUR Mounting.** The SX-Series stainless steel actuator has NAMUR mounting patterns which allows for the direct mounting of both accessories and controls. The use of sandwich NAMUR mounted controls with the Automax SX-Series stainless steel actuator allows for a compact design requiring no tubing or fittings. The NAMUR mounting pattern maintains a lower mounting profile for accessories such as limit switches and positioners.
- 2. Corrosion Resistant Materials.** All external components are 300 series stainless steel. Optional stainless steel pistons and springs are available for internal corrosion resistance. Optional stainless steel APS2 air purge module is available for standard stainless steel spring return actuators.
- 3. Bi-directional Travel Stops.** Travel stops allow for adjustment of the clockwise and counterclockwise positions. The unique travel stops allow for 5° overtravel in each position and unlimited undertravel adjustment in each direction.
- 4. Field Reversible Action.** Field reversible action accomplished by simply rotating the pistons 180°.
- 5. Interchangeability.** One design for spring return and double acting actuators allows for maximum interchangeability.
- 6. Concentric Nested Spring Design.** Significantly reduces the number of parts and allows for maximum spring gage and cycle life.
- 7. Broad Size Range.** Broad size range offers optimum actuator sizing.
- 8. ISO Valve Mounting Pattern.**



Flowserve Corporation
Flow Control Division
Automation Business Unit

765 South 100 East
Provo, Utah 84606
www.flowserve.com

Phone: 801 373 3028
Facsimile: 801 489 2228
Email: actuators@flowserve.com

Standard Springs SR Torque Outputs (in lbs.)

Model	No	Spring		Air Supply					
		End	Break	60 Psig		80 Psig		100 Psig	
				End	Break	End	Break	End	Break
SXL050	5	36	55	56	76				
	6	43	64	46	69				
	7	49	73	35	63	74	102		
	8	61	92	15	49	54	88	93	127
	9	73	110			34	74	73	113
SXL063	6	68	102	103	141				
	7	79	119	85	128				
	8	90	136	66	116				
	9	102	153			119	175		
	10	113	170			100	163		
	11	124	186			82	150	153	222
	12	135	203					135	210
SXL085	6	141	211	215	293				
	7	164	246	177	267				
	8	188	282	138	241				
	9	211	317			248	365		
	10	235	352			209	339		
	11	258	387			171	313	320	463
SXL100	12	282	422					281	437
	6	260	390	397	541				
	7	303	455	325	493				
	8	347	520	253	445				
	9	390	585			457	673		
SXL115	10	433	651			385	625		
	11	477	716			313	577	589	853
	12	520	781					518	805
	6	430	645	656	894				
	7	502	753	537	814				
	8	573	860	418	735				
SXL125	9	645	968			756	1112		
	10	717	1075			637	1033		
	11	789	1183			518	954	975	1410
	12	860	1290					856	1331
	6	610	915	930	1267				
	7	712	1067	761	1155				
	8	813	1220	593	1042				
SXL150	9	915	1372			1071	1577		
	10	1017	1525			903	1464		
	11	1118	1677			734	1352	1381	1999
	12	1220	1830					1213	1887
	6	1098	1648	1673	2280				
	7	1281	1922	1369	2078				
SXL150	8	1465	2197	1066	1875				
	9	1648	2471			1927	2837		
	10	1831	2746			1624	2635		
	11	2014	3020			1320	2432	2485	3597
	12	2198	3295					2182	3394

Spring chart SXL050 ②

Spring Group	Spring Combination ①		
	#1 Spring (inner)	#2 Spring (low rate outer)	#3 Spring (high rate outer)
4	1 ③	1 ③	
5		2	
6	2	1	
7	1	2	
8	2	2	
9	2		2

Note: ① #1 Spring has one color code dot
#2 Spring has two color code dots
#3 Spring has three color code dots
② SXL050 has maximum of 2 springs per endcap
③ Install springs on opposite sides

Spring chart SXL063-SXL200

Spring Group	Spring Combination ①		
	#1 Spring (inner)	#2 Spring (middle)	#3 Spring (outer)
4		2	
5		1 ③	1 ③
6			2
7	1		2
8	2		2
9	1 ③	1 ③	2
10		2	2
11	1	2	2
12	2	2	2

Double Acting Torque Outputs (in lbs.)

Actuator	Air Pressure (psi)				
	40	60	80	100	120
SXL050	78	116	155	194	233
SXL063	144	216	288	360	432
SXL085	299	449	598	748	898
SXL100	552	828	1104	1380	1656
SXL115	913	1369	1826	2282	2738
SXL125	1294	1941	2588	3236	3883
SXL150	2329	3494	4658	5823	6988

Note: For additional air supply pressures, consult factory or your AutoSize software program.

Specifications:

Temperature: 0°F to 300°F (-18°C to 149°C) Viton Seals (Standard)
-55°F to 175°F (-48°C to 80°C) Low Temperature Seals
Pressure: Maximum: 120 psig
Media: Dry or lubricated noncorrosive gas compatible with Viton seals



Flowserve Corporation
 Flow Control Division
 Automation Business Unit

765 South 100 East
 Provo, Utah 84606
 www.flowserve.com

Phone: 801 373 3028
 Facsimile: 801 489 2228
 Email: actuators@flowserve.com

Stainless Steel Springs SR Torque (in lbs.)

Model	Air Supply										
	Spring			40 psi		60 psi		80 psi		100 psi	
	No.	End	Break	End	Break	End	Break	End	Break	End	Break
SX063	4	45	67	79	103	130	155				
	5	56	84	61	92	112	143				
	6	67	100	43	80	94	131				
	7	79	117			75	118	126	169		
	8	89	134			57	106	108	157		
	9	101	151					88	144	140	195
	10	112	167					71	132	122	183
	11	124	185							102	170
	12	136	203							83	157
SX100	4	173	260	302	698	498	594				
	5	211	318	268	356	434	552				
	6	249	375	174	314	370	510				
	7	298	447			291	456	487	653		
	8	336	505			227	414	423	611		
	9	379	571					350	562	547	759
	10	422	635					280	515	476	711
	11	466	701							403	663
	12	510	767							330	615
SX125	4	406	630	684	932	1144	1392				
	5	495	758	542	834	1002	1294				
	6	584	887	401	735	861	1195				
	7	698	1073			654	1069	1115	1530		
	8	787	1201			513	971	973	1431		
	9	889	1355					803	1318	1263	1778
	10	990	1516					625	1207	1085	1667
	11	1092	1670							915	1554
	12	1195	1824							745	1440

Flowserve Corporation
Flow Control Division
Automation Business Unit

765 South 100 East
Provo, Utah 84606
www.flowserve.com

Phone: 801 373 3028
Facsimile: 801 489 2228
Email: actuators@flowserve.com

Dimensions:

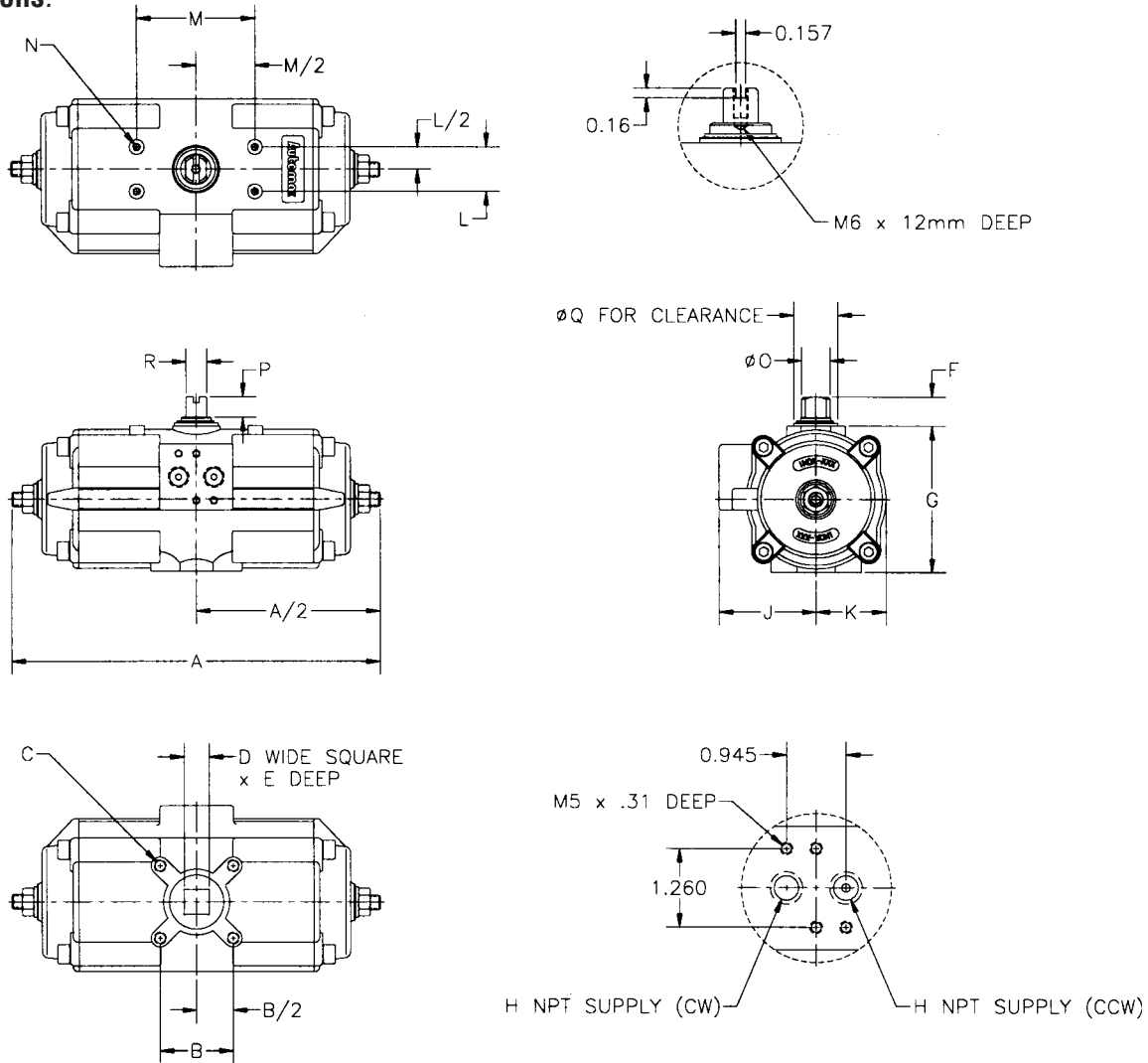

- ① Actuator shown in the full clockwise (CW) position as viewed from the accessory side.
- ② Accessory mounting holes not for gear override or stop block. Consult factory.
- ③ Use studs only to mount. Bolts are not recommended.

④ Air consumption per 90° = $\frac{V}{1728} \left(\frac{\text{Supply Pressure} + 14.7}{14.7} \right)$
(Standard cubic feet)

Model	ISO Pattern	A	B	C SQUARE	D	E	F	G	H NPT	J	K	M	O	P	Q	R	Weights	Volume		Cycle Time	
																		CW	CWW	CW	CWW
SXL050	F04S11	6.69	1.169	M5 x .31	.433	.47	.79	2.56	1/8	1.85	1.18	3.150	.56	.39	.83	.39	4.85 lbs.	8.2	5.4	.5	.5
SXL063	F05S14	7.95	1.392	M6 x .31	.551	.63	.79	2.56	1/8	2.11	1.44	3.150	.56	.39	.91	.39	7.05 lbs.	16	10	.5	.5
SXL085	F07S17	9.84	1.949	M8 x .31	.669	.79	.79	3.94	1/8	2.60	1.87	3.150	.77	.55	1.18	.55	11.24 lbs.	34	20	.5	.5
SXL100	F07S17	11.65	1.949	M8 x .31	.669	.79	.79	4.57	1/4	2.95	2.17	3.150	.77	.55	1.46	.55	16.09 lbs.	56	38	1	.5
SXL115	F10S22	13.46	2.840	M10 x .31	.866	.98	1.18	5.16	1/4	3.23	2.46	5.118	1.38	.79	1.77	.79	23.14 lbs.	94	65	1	1
SXL125	F10S22	15.83	2.840	M10 x .31	.866	.98	1.18	6.61	1/4	3.43	2.70	5.118	1.38	.79	2.17	.79	38.14 lbs.	128	90	1	1
SXL150	F12S27	19.13	3.480	M12 x .47	1.063	1.14	1.18	6.61	1/4	3.94	3.19	5.118	1.97	.89	2.64	1.42	51.14 lbs.	224	159	2.0	1.5

Flowserve Corporation
Flow Control Division
Automation Business Unit

765 South 100 East
Provo, Utah 84606
www.flowserve.com

Phone: 801 373 3028
Facsimile: 801 489 2228
Email: actuators@flowserve.com

Principle of Operation: (as viewed from top of actuator)

Double Acting

Applying the air pressure to Port 2 drives the pistons outward, which turns the pinion counterclockwise as the air volume on the outside of the pistons exhausts through Port 1.

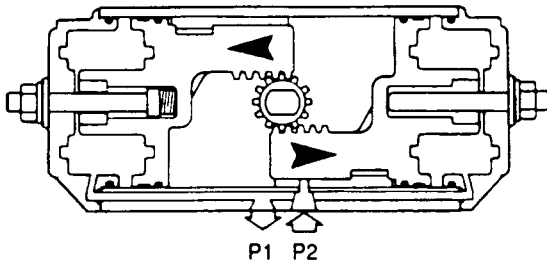

Double Acting

Applying air pressure to Port 1 drives the pistons inward, which turns the pinion clockwise as the air volume on the inside of pistons exhausts through Port 2.

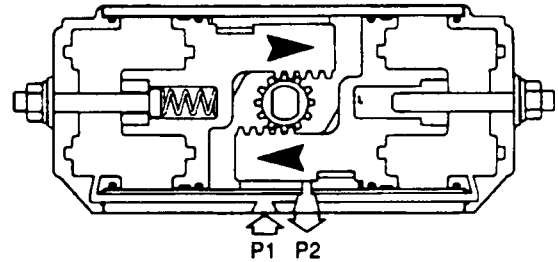

Spring Return (Fail CW)

Applying the air pressure to Port 2 drives the pistons outward, which compresses the springs and turns the pinion counterclockwise as the air volume on the outside of the pistons exhausts through Port 1.

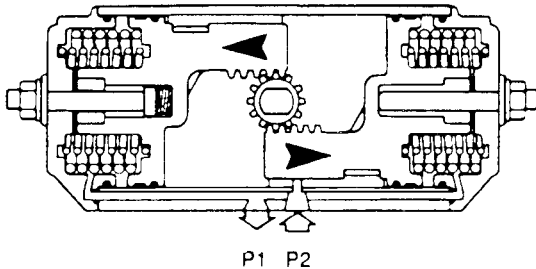

Spring Return (Fail CW)

Exhausting air pressure from Port 2 allows stored energy of the springs to drive the pistons inward, turning the pinion clockwise. Air volume on the outside of the pistons vents through Port 1.

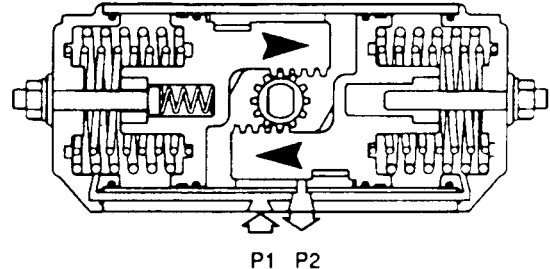

Spring Return (Fail CCW)

Applying the air pressure to Port 2 drives the pistons outward, which compresses the springs and turns the pinion clockwise as the air volume on the outside of the pistons exhausts through Port 1.

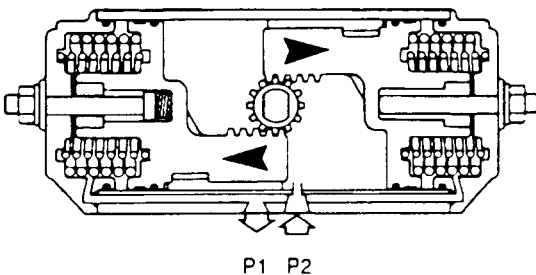

Spring Return (Fail CCW)

Exhausting air pressure from Port 2 allows stored energy of the springs to drive the pistons inward, turning the pinion counterclockwise. Air volume on the outside of the pistons vents through Port 1.

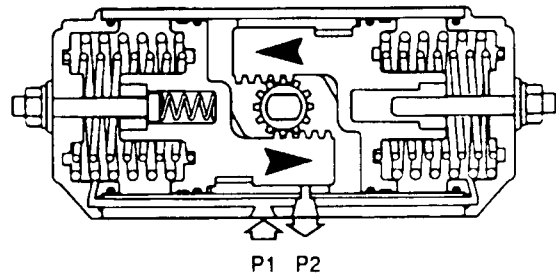

Flowserve Corporation
Flow Control Division
Automation Business Unit

765 South 100 East
Provo, Utah 84606
www.flowserve.com

Phone: 801 373 3028
Facsimile: 801 489 2228
Email: actuators@flowserve.com

Materials of Construction:

Durable construction and corrosion resistant materials/coatings provide protection against the toughest applications in all process industries.

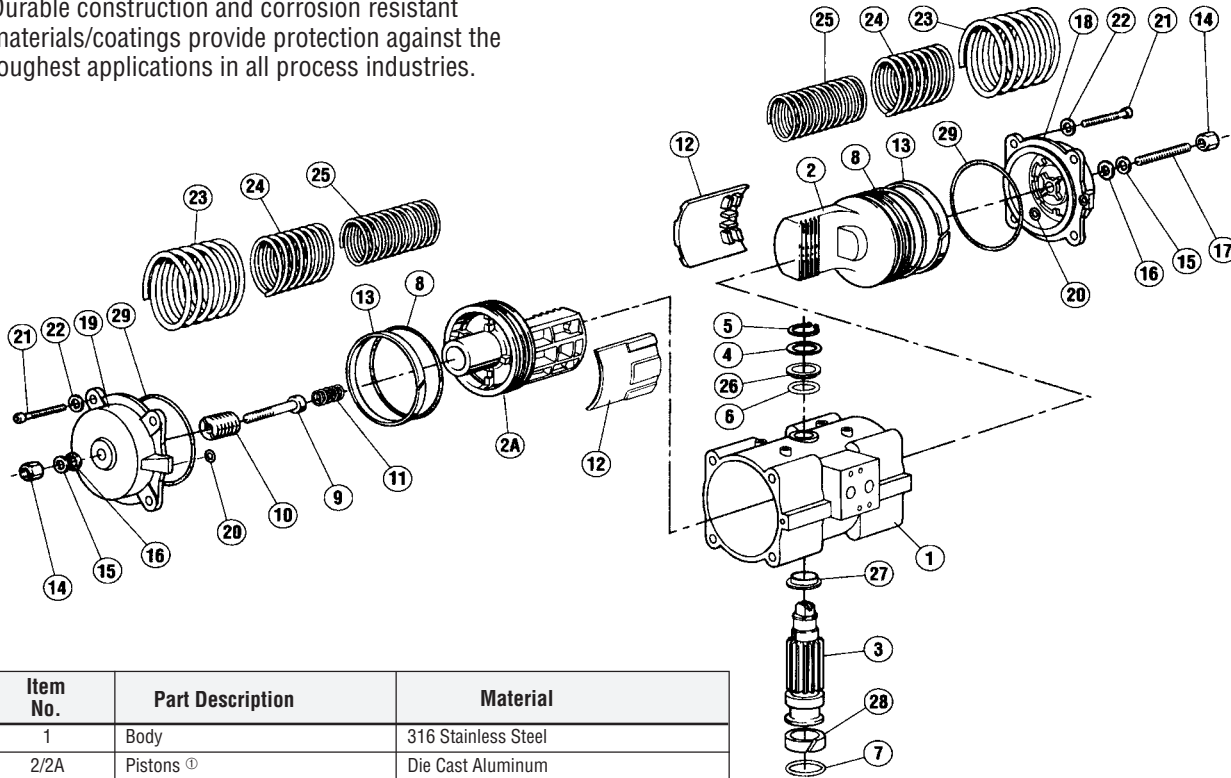

Item No.	Part Description	Material
1	Body	316 Stainless Steel
2/2A	Pistons ①	Die Cast Aluminum
3	Pinion	303 Stainless Steel
4	Pinion Washer ②	304 Stainless Steel
5	Pinion Snap Ring ②	Peek Composite
6	Upper Pinion O-Ring ②	Viton
7	Lower Pinion O-Ring ②	Viton
8	Piston/End Cap O-Ring ②	Viton
9	Inward Travel Stop Bolt	304 Stainless Steel
10	Inward Travel Retaining Nut	304 Stainless Steel
11	Inward Travel Spring	Steel/Plated
12	Piston Guide	Nylon and Molybdenum Disulfide
13	Piston Guide Band	Nylon and Molybdenum Disulfide
14	Stop Bolt Retaining Nut	304 Stainless Steel
15	Stop Bolt Washer	304 Stainless Steel
16	Stop Bolt O-Ring ②	Viton
17	Stop Bolt	304 Stainless Steel
18	Right End Cap	316 Stainless Steel
19	Left End Cap	316 Stainless Steel
20	End Cap Supply O-Ring ②	Viton
21	End Cap Screw	304 Stainless Steel
22	End Cap Screw Washer	304 Stainless Steel
23	Outer Spring ①	Spring Steel/Coated
24	Middle Spring ①	Spring Steel/Coated
25	Inner Spring ①	Spring Steel/Coated
26	Pinion Thrust Washer ②	Peek Composite
27	Upper Pinion Bearing ②	Peek Composite
28	Lower Pinion Bearing	Peek Composite

Note: ① Optional stainless steel available.

② Recommended Spare Parts (included in seal kits).

Temperature Ratings

Standard ¹	Viton	0°F to +300°F
Low Temp ²	Silicon-based	-55°F to +175°F

Notes:

¹ For standard applications, use multi-purpose polymer fortified grease, such as Dubois Chemicals MPG-2.

² For low temperature and high temperature applications, use Dow 55 O-ring lubricant.

Flowserve Corporation
Flow Control Division
Automation Business Unit

765 South 100 East
Provo, Utah 84606
www.flowserve.com

Phone: 801 373 3028
Facsimile: 801 489 2228
Email: actuators@flowserve.com

Installation & Maintenance: Refer to LMR0021-0 (B 00150-0)

How to Order:

The SX-Series stainless steel actuator shall be specified by ordering:

- **SERIES**

- SX - Super Nova Stainless Steel (ISO 5211, metric threads, NPT)

- **PINION STYLE**

- L - ISO 5211 - Square

- **MODEL**

- 050, 063, 085, 100, 115, 125, 150

- **ACTION**

- D - Double Acting

- S - Spring Return FCW (Fail Clockwise)

- C - Spring Return FCCW (Fail Counterclockwise)

- **NUMBER OF SPRINGS**

- 04, 05, 06, 07, 08, 09, 10, 11, 12

- **OPTIONS**

- **SEAL MATERIAL**

- Blank - Viton (Standard)

- L - Low Temperature

- **UNIT MATERIAL**

- Blank - Standard

- K - K-mass Coated

- F - Polished

- **OPTIONS**

- R - Extra Long Travel Stops

- M - Stainless Steel Springs

- P - Stainless Steel Pistons

- B - Special (Consult Engineering)



Flowserve Corporation
Flow Control Division
Automation Business Unit

765 South 100 East
Provo, Utah 84606
www.flowserve.com

Phone: 801 373 3028
Facsimile: 801 489 2228
Email: actuators@flowserve.com

Page 8 left blank intentionally.