



# *Installation Instructions*

## ***Pac-Seal™ Type 51 and 52***

Mechanical Shaft Seal

---



## Description

The Pac-Seal Types 51 and 52 are similar to the Types 21 and 31 in design, with a crimped head and hex-torque drive system but with a more flexible bellows. The convolution in the seal bellows allows for greater axial movement and shaft deflection than Types 21 and 31. This adds flexibility but reduces pressure capability. Both Types 51 and 52 are available in double seal configurations and balanced versions.

## Type 51 Nomenclature

Figure 1

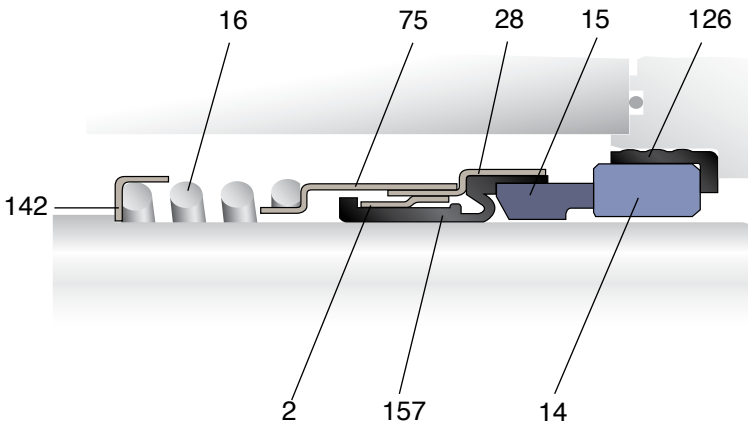

Part Reference	Description
2	Seal Drive/Drive Band
14	Stationary Face/Mating Ring
15	Rotating Face/Primary Ring
16	Spring
28	Shell
75	Drive Adapter
142	Retainer/Spring Retainer
157	Bellows Diaphragm/ Elastomer Bellows

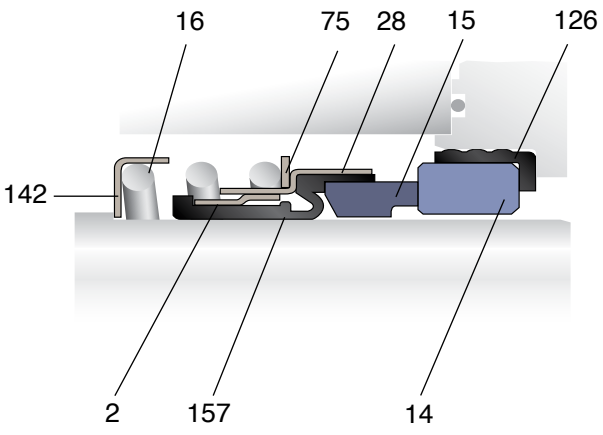

<b>Part Reference</b>	<b>Description</b>
2	Seal Drive/Drive Band
14	Stationary Face/Mating Ring
15	Rotating Face/Primary Ring
16	Spring
28	Shell
75	Drive Adapter
142	Retainer/Spring Retainer
157	Bellows Diaphragm/ Elastomer Bellows

# 1 Equipment Check

---

- 1.1 Follow plant safety regulations prior to equipment disassembly including, but not limited to, the following:
  - Lock out motor and valves
  - Wear designated personal safety equipment
  - Relieve any pressure in the system
  - Consult plant MSDS files for hazardous material regulations
- 1.2 Disassemble pump in accordance with equipment manufacturer's instructions and remove sealing arrangement.
- 1.3 Check Seal documentation for seal design and materials of construction.
- 1.4 Check shaft or pump sleeve outer diameter (OD), seal chamber bore to ensure they are dimensionally within the tolerances shown on the seal assembly drawing.  
(See Figure 3)

## Seal Chamber Requirements

Figure 3

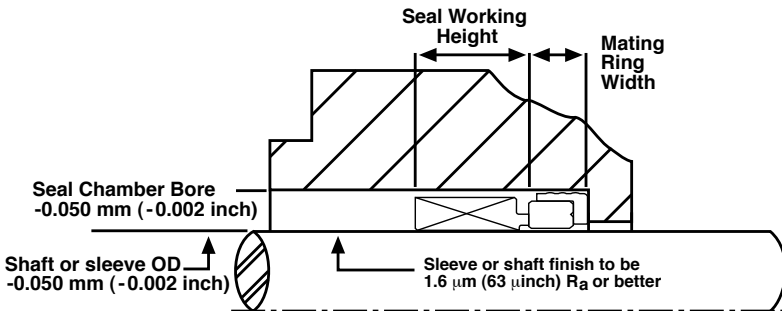

- Bearings must be in good condition
- Maximum lateral or axial movement of shaft (end play) =  $0.25 \text{ mm} (0.010 \text{ inch})$  FIM
- Maximum shaft runout at face of seal housing =  $0.05 \text{ mm} (0.002 \text{ inch})$  FIM
- Maximum dynamic shaft deflection at seal housing =  $0.05 \text{ mm} (0.002 \text{ inch})$  FIM
- Verify proper shaft and bore lead in chamfers are present and within specifications. Difficulty and damage can be observed during seal installation without proper lead in chamfers.

- 1.5 Thoroughly inspect and clean the seal chamber and shaft or pump sleeve. Inspect for corrosion or any defects. Remove all burrs, cuts, dents or defects that might damage gaskets or allow a leak path. Replace worn shaft or pump sleeve.
- 1.6 Check equipment requirements as described in Figure 2. Any measurement different than what is allowed must be brought within specifications.
- 1.7 Handle the seal with care; it is manufactured to precise tolerances. The seal faces are of special importance and should be kept perfectly clean at all times.

## 2 Type 51 and Type 52 Installation

---

- 2.1 Lubricate the shaft or sleeve lightly. Use a water-based lubricant (Pac-Ease recommended). If Pac-Ease is not available use a solution of liquid dish soap in water as lubricant. **Note:** Never use grease or oil as an installation lubricant. Oil used to lubricate the elastomer bellows/cup gasket will significantly reduce the friction drive or anti-rotation capability of the component.
- 2.2 Lubricate the outer diameter (OD) of the stationary elastomer cup gasket or O-ring with Pac-Ease.
- 2.3 Press the stationary seal seat firmly into counter bore ensuring it is bottomed out and squared to the shaft. This can be hand-pressed or machine-pressed into place taking care to protect the sealing face from direct contact with any metal object. Use a piece of plastic between the face and the press or a plastic installation tool when using a press to install the seat. Additional care must be taken during the stationary seat assembly to assure the O-ring or cup gasket is not cut.

- 2.4 Lubricate inner diameter (ID) of the rotating seal head elastomer bellows with Pac-Ease. **Note:** For smaller diameter seals it may be easier to lubricate the shaft.
- 2.5 Clean both rotating and stationary seal faces with a lint free rag and isopropyl alcohol. **Note** Any oil or grease, assembly lubricant, fingerprints, or other residue from the installation process can cause the seal to leak.

## 2.6 **Type 51**

Slide the rotating seal head by hand along the shaft to a completely parallel contact with the stationary seat. Where possible, prior to installation remove the drive adapter (75) in order to expose the back of the elastomer bellows. Apply pressure to the back of the metal shell and elastomer bellows. Applying pressure to both the metal shell and bellows is important to minimize stretching of bellows on the shaft relative to the rotating seal head. If the drive adapter (75) is not able to be removed from the seal assembly it is recommended to push the seal head slightly past its operating position on the shaft, so when the installation force is removed, it springs back into the operating position. Replace the driver adapter if removed. Avoid extreme installation pressure or hammering of the seal.

## **Type 52**

Slide the rotating seal head by hand along the shaft to a completely parallel contact with the stationary seat. Apply pressure to the back of the metal drive adapter/shell and elastomer bellows. Applying pressure to both the metal drive adapter/shell and bellows is important to minimize stretching of bellows on the shaft relative to the rotating seal head. Avoid extreme installation pressure or hammering of the seal.

2.6.1 For back-first installations apply pressure to the outer diameter of the seal. Whenever possible even pressure should be applied to the outer diameter of the seal face, bellows, and outer shell to provide proper installation. Care should be taken not to apply pressure directly to the sealing surface of the seal face to avoid any possible damage. Press the assembly until the back side of the spring (or spring retainer if applicable) is flush and parallel to the equipment. Clean both rotating and stationary seal faces with a lint free rag and isopropyl alcohol. **Note:** Any oil or grease on the seal faces may cause the seal to leak.

2.7 Install spring and spring retainer (if applicable) over shoulder of metal outer shell. Make sure spring correctly engages shoulder of seal head and impeller shoulder or spring shaft retainer.

## **Type 51 and Type 52 Operational Recommendations**

---

3.1 Remove lock outs on equipment and valves

3.2 Do not start up the pump dry to check motor rotation or for any other reason. Open valves to flood pump with product fluid. Vent air from the casing of the pump and the seal chamber before start-up.

3.3 Observe the start-up. If the seal runs hot or squeals do not allow the pump to run for any extended time.

3.4 The seal is designed to resist corrosion through proper material selection. Do not expose the seal materials of construction to products outside of their corrosion limits. Consult Flowserve for chemical resistance recommendations.

3.5 Do not exceed pressure and speed limits established for the seal.

3.6 Do not exceed the temperature limits of the seal based on the materials of construction.



TO REORDER REFER TO  
B/M # \_\_\_\_\_  
F.O. \_\_\_\_\_

FIS219eng ORG 11/13 Printed in USA

**To find your local Flowserve representative**  
and find out more about Flowserve Corporation,  
visit [www.flowserve.com](http://www.flowserve.com)

**Flowserve Pac-Seal**  
1020 Davey Road  
Unit 100  
Woodridge, Illinois 60521 USA  
Telephone: 630 910 2500  
EFax: 469 420 4181

Flowserve Corporation has established industry leadership in the design and manufacture of its products. When properly selected, this Flowserve product is designed to perform its intended function safely during its useful life. However, the purchaser or user of Flowserve products should be aware that Flowserve products might be used in numerous applications under a wide variety of industrial service conditions. Although Flowserve can provide general guidelines, it cannot provide specific data and warnings for all possible applications. The purchaser/user must therefore assume the ultimate responsibility for the proper sizing and selection, installation, operation, and maintenance of Flowserve products. The purchaser/user should read and understand the Installation Instructions included with the product, and train its employees and contractors in the safe use of Flowserve products in connection with the specific application.

While the information and specifications contained in this literature are believed to be accurate, they are supplied for informative purposes only and should not be considered certified or as a guarantee of satisfactory results by reliance thereon. Nothing contained herein is to be construed as a warranty or guarantee, express or implied, regarding any matter with respect to this product. Because Flowserve is continually improving and upgrading its product design, the specifications, dimensions and information contained herein are subject to change without notice. Should any question arise concerning these provisions, the purchaser/user should contact Flowserve Corporation at any one of its worldwide operations or offices.

© 2013 Flowserve Corporation