



---

---

---

---

---

---

# ZK 29

# GB

## Installation Instructions 810685-00

Control Valve with ZK Radial Stage Nozzle



Flow Control Division



# Contents

Page

## Important Notes

Usage for the Intended Purpose .....	3
Safety Note .....	3
Warning .....	4
Ratings Pursuant to Article 9 of the Pressure Equipment Directive .....	4

## Explanatory Notes

Scope of Supply .....	5
Description .....	5
Function .....	6
Technical Data .....	7
Pressure/Temperature Rating .....	7
Material .....	8
Corrosion Resistance .....	8
Nominal Sizes .....	8
Connections .....	8
Operation .....	8
Capacity Charts .....	9
$K_{vs}$ Values and Actuator Selection Data .....	9

## Operating Procedure

Installation .....	10, 11
Commissioning .....	11
Operation .....	12
Maintenance .....	12, 13

## Repairs

Repair .....	14
Spare Parts .....	14

## Important Notes

### Usage for the Intended Purpose

The control valve, series ZK 29, is intended solely for cutting off and/or regulating the flow of fluids consisting of water, steam, or steam condensate.

Its use is permissible only within the allowable limits of pressure and temperature and only if the chemical and corrosive influences on the pressure equipment are taken into account.

Before installation and operation, a check must be performed to ascertain that the valve is resistant to the medium in the operational conditions that will exist.

Opening of the valve body and/or structural changes may be performed only if the manufacturer's written permission is obtained.

Any type of use differing from the usage described above must be considered as improper.

The resulting risk will have to be borne by the user alone. The manufacturer hereby expressly rejects any claims for any resulting damage.

### Safety Note

The control valve ZK 29 must not be installed, removed, commissioned, operated or maintained by anyone other than qualified staff.

"Qualified staff" are persons who are familiar with the procedures for installation, removal, commissioning, operation and maintenance of the product, and who have qualifications appropriate for their work, for example staff who have received the following:

- Training as specialists.
- Training or instruction in the use of appropriate safety procedures in accordance with the standards of safety engineering.
- Training or instruction in first aid and in accident prevention regulations.

For installation, removal, commissioning, operation and maintenance, every person who works with the control valve must have read and understood the complete installation instructions. Furthermore, responsibilities must have been defined clearly and unambiguously and must be adhered to.

In addition to these installation instructions, the documents issued by the manufacturers of the actuators, and in particular the safety information contained in these documents, must be observed.

Usage of the control valve ZK 29 for the intended purpose includes compliance with the rules and notes in these installation instructions for installation, removal, commissioning, operation and maintenance.

The operating company must ensure that, whenever the control valve ZK 29 is being operated, it is in perfect condition.

Working methods that jeopardise safety must not be used.

## Important Notes

(continued)

### Warning



#### Danger

If the control valve is used in an inexpert or improper manner by unqualified staff, it can cause danger to life and limb for the user or for third parties, possibly resulting in death.

During operation, the control valve ZK 29 is under pressure. In this condition, screws, nuts or bolts must not be slacked. Hot water or steam could flow out and could cause severe scalding over the entire body.

During operation, the valve might be hot. If the valve is touched when in the operational condition, severe burns are possible. It must be ensured that, when handwheels are being operated, the operator wears gloves.

Any installation or removal work may only be performed when the equipment is at zero pressure and has cooled down. When such work is to be done, the pressure in the pipes upstream and downstream of the valve must have been reduced to zero and the valve must have cooled down sufficiently. It must be ensured that, during the work, the system section in which pressure has been reduced to zero cannot be accidentally put back into operation. The shut-off valves needed for this purpose must be separately secured and marked. In addition, it must be ensured that the actuators of the valve are not in the connected state. The connection to the energy supply (electric, pneumatic, hydraulic) must be disconnected and must be secured to prevent it from being operated accidentally. One or more warning notices, for example containing the text "DO NOT SWITCH ON", must be displayed in a clearly visible manner at each operating element.

### Ratings Pursuant to Article 9 of the Pressure Equipment Directive

Fluid	Gaseous		Liquid	
	1	2	1	2
Use	No	Yes	No	Yes

Category	Exception according to Art.3.3	I	II	III	IV (safety equipment)
Nominal size of connection, DN	25	32 – 100	125	150	---
CE marking	No	Yes	Yes	Yes	---

The control valve may only be used in accordance with the above-mentioned ratings pursuant to Article 9 of the Pressure Equipment Directive. Any other type of use must be considered as improper.

## Explanatory Notes

### Scope of Supply

- Control valve ZK 29 with or without an attached actuator, according to the order
- Installation instructions for the control valve
- Parts list with drawing
- Operation instructions for the actuator
- Acceptance certificates according to the order

### Description

The control valve ZK 29 is used to reduce large differential pressures. It is used mainly in industrial plants and power stations in which ease of maintenance and high resistance to wear are required.

The valve consists of the valve body, a yoke suitable for the various actuators, and a ZK radial stage nozzle<sup>®</sup> with valve plug integrated in the valve body to act at the control element. Depending on requirements, the bodies are designed as straight-through or angle versions.

The control valve can be operated by means of various actuators, e.g. electric rotary actuators, pneumatic actuators and lever actuators, or by means of a handwheel.

Special equipment is available, such as sampling valves, a sealing-fluid connection and self-tightening stuffing boxes.

If the operating conditions of the plant change, the  $K_{vs}$  value and the characteristic curve of the control valves can be adapted to suit the new conditions by turning of the sleeve insert of the ZK radial stage nozzle, without having to remove the valve.

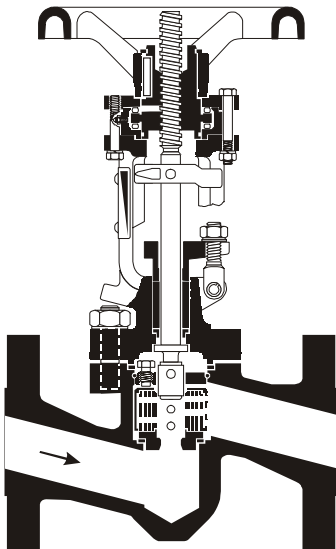

Control valve ZK 29/14 DN 25 with handwheel and flanged ends

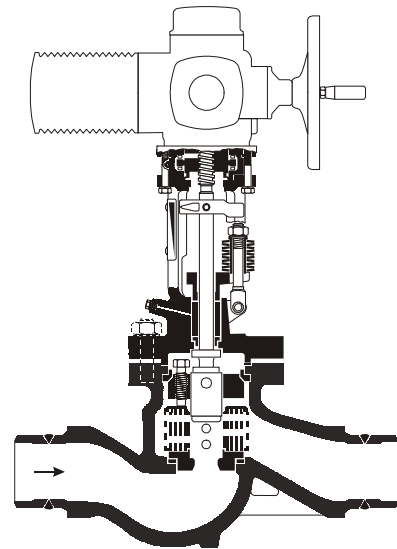

Control valve ZK 29/14 DN 80 with rotary actuator, butt-weld ends, sealing-fluid connection and self-tightening stuffing box (special equipment)

## Function

Every control valve is equipped with a ZK radial stage nozzle .

This is a system comprising several sleeves nesting within one another and containing radial orifices drilled in them. By rotation of the sleeves, the orifices are shifted relative to one another, thus forming a large number of throttling points in parallel, with turbulence chambers (expansion chambers) in between.

The throughput through the ZK radial stage nozzle is set by means of the valve plug. Depending on its position, this valve plug opens up the individual orifices partially or completely, thus producing different flow rates.

As a result of this design, the pressure drop is reduced in steps and the medium flowing through is split up into many partial flows. This ensures high resistance to wear and reduces the noise level.

On the valve plug, there is a control edge which is separate from the seat surface and closes the orifices of the sleeve insert before the valve plug comes to rest completely against the seat ring. As a result, wear is prevented on the surfaces of the seat. Because of the multiple, step-by-step expansion in the turbulence chambers, the pressure drop in the region of the seat is minimised.

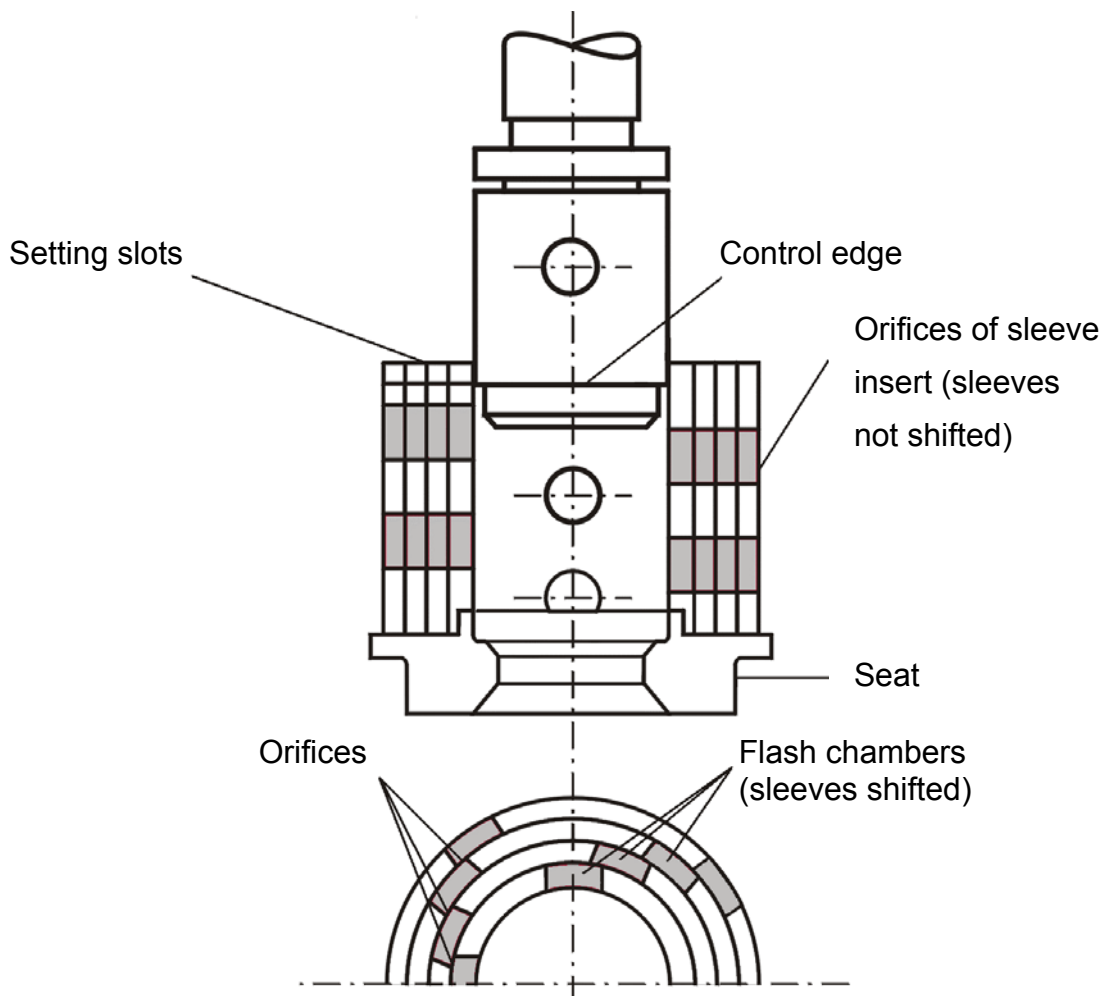

Control valve ZK 29: cross section of the radial stage nozzle

## Technical Data



### Important

For the technical data of the control valve ZK 29, see the name plate.

Valve position

Name plate drawing

Name plate data

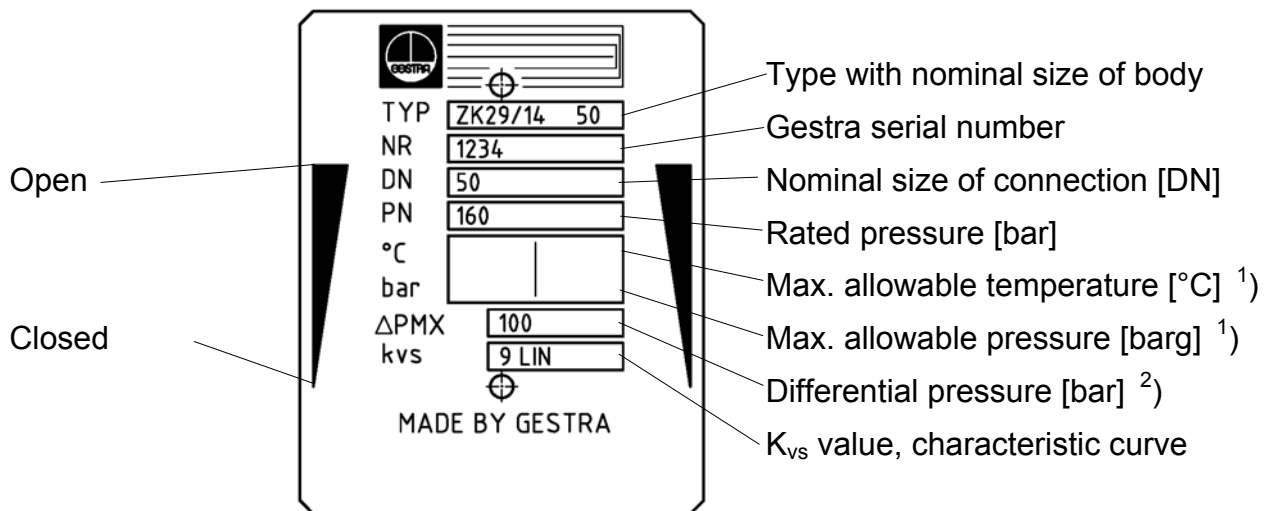

<sup>1)</sup> If there is no rated pressure stated on the name plate, the maximum allowable pressure limits are stated together with the associated temperatures.

Example:    °C        300 | 530  
              barg        100 | 38

<sup>2)</sup> The statement of differential pressure corresponds to valve inlet pressure minus valve outlet pressure.

The scope and layout of the name plate data comply with EN 19.

## Pressure/Temperature Rating



### Important

In the installation instructions, standard pressure/temperature ratings are described. For possible deviations, please see the name plate of the control valve.

Max. allowable pressure	PMA [barg]	160	100	62
Max. allowable inlet temperature	TMA [°C]	300	510	530
Max. allowable differential pressure	ΔPMX [bar]	100		

## Explanatory Notes

(continued)

### Material



#### Important

In the installation instructions, standard materials are described. For possible deviations, please see the parts list supplied.

Body DN 25 and 50	13 CrMo 4 4 (1.7335)
Body DN 80, 100 and 150	GS-17 CrMo 5 5 (1.7357); however, butt-weld ends 13 CrMo 4 4 (1.7335).
Spindle	X 39 CrMo 17-1 (1.4122)
Valve plug and valve seat	X 90 CrMoV 18 hardened (1.4112)

### Corrosion Resistance

If the unit is used for the intended purpose, its safety is not impaired by corrosion.

### Nominal Sizes

The control valve ZK 29 is delivered with bodies of nominal size DN 25, DN 50, DN 80, DN 100 and DN 150. Different connection sizes are possible as special versions.

To determine the nominal size, the nominal size of the control valve's connection, which is stated on the name plate, is definitive.

### Connections

The control valve ZK 29 is normally delivered with butt-weld ends. Alternatively if desired, socket-weld ends or flanges are possible.

### Operation

The control valve ZK 29 is suitable for the following actuators:

- ZK 29/01 Manual operation, not convertible to electric rotary actuators (DN 25 to DN 80 only, otherwise ZK 29/14 with handwheel)
- ZK 29/13 Electric linear actuator
- ZK 29/14 Version with insert bush of form B1, DIN EN ISO 5210, for attaching an electric rotary actuator or a handwheel, whichever is desired
- ZK 29/20 Pneumatic diaphragm-actuator
- ZK 29/30 Lever for quarter-turn actuator (next to valve)
- ZK 29/31 Lever prepared for attaching of a quarter-turn actuator to the valve
- ZK 29/40 Hydraulic cylinder

## Capacity Charts

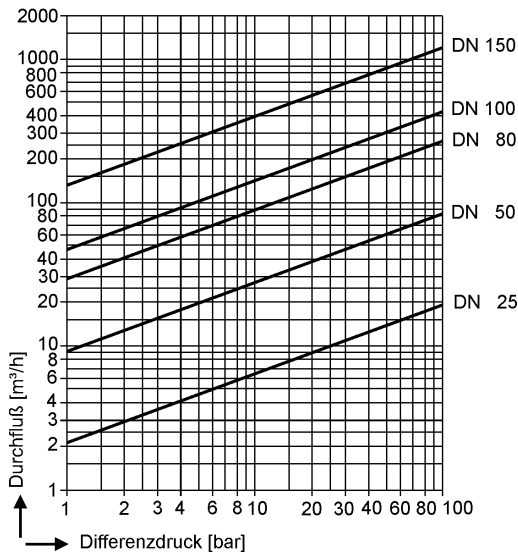

Cold water

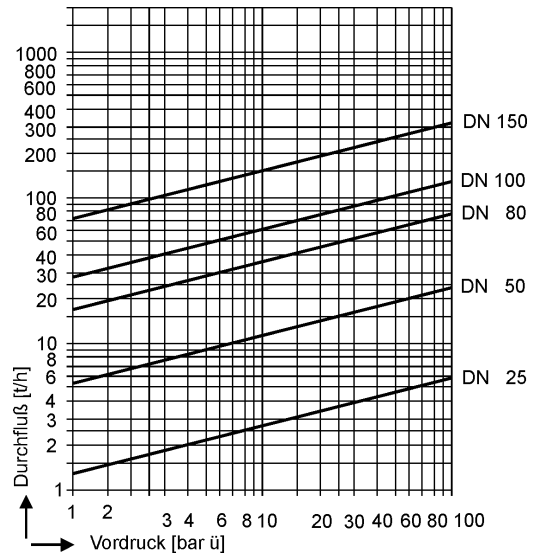

Hot water  $t_s - 5\text{ K}$

The charts show the maximum flowrates of cold and hot water at the extreme regulation position with linear characteristic curves and maximum  $K_{vs}$  value.

## $K_{vs}$ Values and Actuator Selection Data



### Important

In the installation instructions, standard values are described. For possible deviations, please see the name plate of the control valve.

DN	Characteristic	$K_{vs}$			Valve stroke [mm]	Revol- utions for full stroke of valve	Max. admiss. torque for opening / closing [Nm]	Type/size of actuator DIN ISO 5210
		[m <sup>3</sup> /h]						
25	Linear	0.7	1.4	2.1	16	4	20	F10 - B1
25	Equal %	0.7	1.4	2.1	16	4	20	F10 - B1
50	Linear	3	6	9	33	8.3	60	F10 - B1
50	Equal %	3	5,5	8	33	8.3	60	F10 - B1
80	Linear	14	21	28	45	11.3	60	F10 - B1
80	Equal %	9	15	21	45	11.3	60	F10 - B1
100	Linear	20	33	46	60	12	90	F10 - B1
100	Equal %	15	25	35	60	12	90	F10 - B1
150	Linear	70	100	130	90	15	215	F14 - B1
150	Equal %	60	85	110	90	15	215	F14 - B1

# Operating Procedure

## Installation

It is highly advisable to have the installation work done by qualified staff in the manner described by these installation instructions. The manufacturer will not accept liability for damage resulting from improper installation.

In addition, the installation instructions issued by the actuator manufacturers must be observed.

During installation, it must be ensured that the installation space surrounding the valve is large enough for the purposes of installation, removal, operation and maintenance.

Please check whether the weight of the valve makes an additional support necessary.

In the case of installation with a horizontal valve-spindle and a pneumatic actuator, the weight of the actuator must be supported separately.

For the installation work, hoisting gear must be chosen which is designed for the weights concerned.

The control valves may only be hoisted by the body and/or by the yoke of the valve.

During hoisting, damage to the actuator, the stuffing box and the lubricating device must be avoided.

The control valve ZK 29 is welded into place directly into the pipe or is mounted between flanges, depending on the connection facilities that are present.

In the case of welding-connections, the statutory and industrial rules for welding-connections must be observed. Before welding, the welding locations must be cleaned.



### Important

The valve is welded into place in the assembled state; any heat treatment that is necessary for the welded joints can likewise be performed in the assembled state. It must be ensured here that the region affected by the heat is limited to the welded joints.

After the valve has been welded into place, it is recommended that it should then be opened fully and flushed with water.

Flushing with caustic agents may only be performed if approved by the manufacturer.

In the case of flange connections, precise positioning of the seals between the flanges must be ensured. Before installation, the sealing surfaces must be cleaned.

Before the control valve is installed, all transportation packaging and all coverings of connections must be removed.

## Operating Procedure (continued)

### Installation (continued)



#### Important

Attention must be paid to the direction of flow. It is indicated by an arrow on the body.

Basically, the valve can be installed with any orientation. As viewed in the direction of flow, the normal installation orientation of the control valve is horizontal with the spindle vertical and the stuffing box pointing upwards.

In the case of angle valves, flow normally takes place over the valve plug.

In the case of units with actuators, the installation rules issued by the actuator manufacturers must be observed.

### Commissioning

The task of commissioning the control valve is performed when the valve is put into operation for the first time, and also after repairs.

Commissioning may only be carried out by qualified staff who have read and understood the installation instructions.

For the actuators, the additional documents issued by the manufacturers must be observed.

Before commissioning, a check must be performed to ensure that all fastenings have been securely tightened.

Commissioning does not require any additional work on the valve.

Unless agreed otherwise, the control valve is delivered in the closed state. The travel distance of the valve plug is stated on the name plate.

During the task of commissioning, all connections and seals on the valve must be checked for leaks. Any leaks must be corrected immediately. In the case of flanged connections, this is done by tightening the nuts; it can also be done on the valve by tightening the stuffing box if necessary.

In the case of pipes at high temperatures, the valves should not be suddenly exposed to the high temperatures. Here, slow warming-up should be performed.

## Operating Procedure (continued)

### Operation

The control valve ZK 29 may only be operated by qualified staff who have read and understood the installation instructions. Additional installation instructions issued by the manufacturers of the actuators must be observed.



#### Danger

During operation, the control valve ZK 29 is under pressure. In this condition, if flanged connections, sealing plugs or the stuffing box is slackened, hot water or steam will flow out and could cause severe scalding over the entire body. There is danger to life and limb for the user or for third parties, possibly resulting in death.

During operation, the valve is hot. If the valve is touched when in the operational condition, severe burns are possible. It must be ensured that, when handwheels are being operated, the operator wears gloves.

During operation, the spindle is moved. The moving parts of the control valve and of the actuator must definitely not be touched; otherwise, your hands might be crushed.

### Maintenance

The control valve ZK 29 may only be maintained by qualified staff. "Qualified staff" are persons who have the necessary qualifications for their work and are familiar with the product.

The additional documents issued by the actuator manufacturers must be observed.



#### Danger

During operation, the spindle is moved. The moving parts of the control valve and of the actuator must definitely not be touched; otherwise, your hands might be crushed.

## Operating Procedure (continued)

### Maintenance (continued)

The following maintenance work must be performed:

Type of maintenance	Time interval	Activities
Inspection	Quarter-yearly	Checking the stuffing box for leaks <sup>1)</sup> (visual inspection)
Inspection	Quarter-yearly	Checking that connections, body seal, valve spindle and threaded spindle are free of wear, are clean, and are not leaking (visual inspection)
Inspection	Quarter-yearly	Checking of seat tightness
Inspection	Annually	Checking that the fastening screws of the valve actuator are seated securely, and tightening them if necessary
Lubrication	Quarter-yearly	Lubricating the spindle bearing with lithium-saponified grease with penetration grade 2 with MoS <sub>2</sub> additive <sup>2)</sup>
Inspection	Every three years	Checking by Gestra specialists to ensure that the internal parts and threaded spindle are not damaged

<sup>1)</sup> Replenishment or exchange of the stuffing box rings may only be performed when there is no pressure in the valve. In particular, the safety information and danger notes in the section entitled "Important Notes" must be observed.



#### Important

The task of opening the body may only be performed by specialists from Gestra.

<sup>2)</sup> Lubricants recommended by the manufacturer are:

- Shell Retinax AM with MoS<sub>2</sub>
- DEA Glissando MEP2

## Repairs

### Repair

Repair work on the control valve ZK 29 may only be performed by specialists from Gestra.

Opening the valve body and making structural changes are regarded as being improper activities.

The resulting risk will have to be borne by the user alone. The manufacturer hereby expressly rejects any claims for any resulting damage.

For maintenance and repair, only original Gestra spare parts may be used.

### Spare Parts

For every control valve ZK 29, a separate parts-list with the associated overall drawing is supplied as well by the manufacturer.

When spare parts are being ordered, the necessary spare-part numbers must be taken from that list.

Spare parts can also be ordered directly from Gestra by quoting the Gestra serial number stated on the name plate.

## Great Britain

### Flowserve Flow Control (UK) Ltd.

Burrell Road, Haywards Heath  
West Sussex RH 16 1TL  
Tel. 00 44 14 44 / 31 44 00  
Fax 00 44 14 44 / 31 45 40  
E-mail: sales@flowserve.com

## France

### Flowserve Flow Control S.A.S.

10 Avenue du Centaure, BP 8263  
F-95801 CERGY PONTOISE CEDEX  
Tél. 00.33.1 / 34 43 26 60  
Fax 00.33.1 / 34 43 26 87  
E-mail: contact@gestra.fr

## España

### GESTRA ESPAÑOLA S.A.

Luis Cabrera, 86-88  
E-28002 Madrid  
Tel. 00 34 91 / 5 152 032  
Fax 00 34 91 / 4 136 747; 5 152 036  
E-mail: gestra@gestra.es

## Italia

### Flowserve S.p. A

Divisione Italgestra  
Via Prealpi, 30 – 20032 Cormano (MI)  
Tel. 00 39 02 / 66 32 51  
Fax 00 39 02 / 66 32 55 60  
E-mail: info@italgestra.it

## Portugal

### Flowserve Portuguesa, Lda.

Av. Dr. Antunes Guimarães, 1159  
Porto 4100-082  
Tel. 0035122/6198770  
Fax 00351 22 / 6 10 75 75  
E-mail: gestra@gestra.pt



## GESTRA GmbH

Postfach 10 54 60, D-28054 Bremen, Münchener Str. 77, D-28215 Bremen  
Telefon +49 (0) 421 35 03 - 0, Telefax +49 (0) 421 35 03 - 393  
E-Mail gestra.gmbh@flowserve.com, Internet www.gestra.de

**A Unit of Flowserve Corporation**