

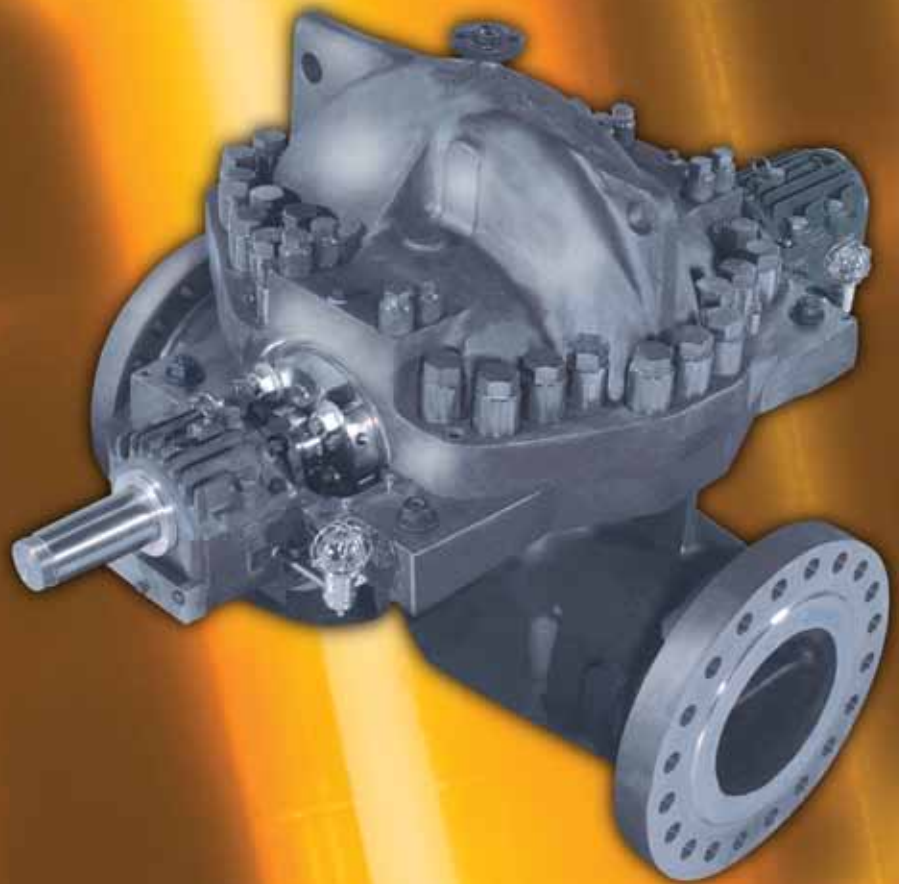

DVSH
***Heavy-Duty, Between Bearings, Axially Split,
Single-Stage, Double-Suction Pump***

ISO 13709/API 610 (BB1)



Experience In Motion

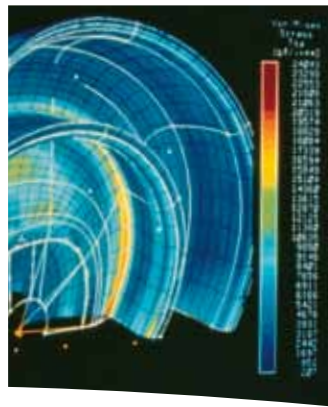

Pump Supplier to the World

Flowserve is the driving force in the global industrial pump marketplace. No other pump company in the world has the depth or breadth of expertise in the successful application of pre-engineered, engineered and special purpose pumps and systems.

Life Cycle Cost Solutions

Flowserve is providing pumping solutions which permit customers to reduce total life cycle costs and improve productivity, profitability and pumping system reliability.

Market Focused Customer Support

Product and industry specialists develop effective proposals and solutions directed toward market and customer preferences. They offer technical advice and assistance throughout each stage of the product life cycle, beginning with the inquiry.

Broad Product Lines

Flowserve offers a wide range of complementary pump types, from pre-engineered process pumps, to highly engineered and special purpose pumps and systems. Pumps are built to recognized global standards and customer specifications.

Pump designs include:

- Single-stage process
- Between bearing single-stage
- Between bearing multistage
- Vertical
- Submersible motor
- Rotary
- Reciprocating
- Nuclear
- Specialty

Product Brands of Distinction

ACEC™ Centrifugal Pumps

Aldrich™ Pumps

Byron Jackson® Pumps

Calder™ Energy Recovery Devices

Cameron™ Pumps

Durco® Process Pumps

Flowserve® Pumps

IDP® Pumps

Lawrence Pumps®

Niigata Worthington™ Pumps

Pacific® Pumps

Pleuger® Pumps

Scienco™ Pumps

Sier-Bath® Rotary Pumps

TKL™ Pumps

United Centrifugal® Pumps

Western Land Roller™ Irrigation Pumps

Wilson-Snyder® Pumps

Worthington® Pumps

Worthington Simpson™ Pumps

DVSH
Heavy-Duty,
Between Bearings,
Axially Split, Single-Stage
Double-Suction Pump
 ISO 13709/API 610 (BB1)



Unequaled Might, Unequaled Operating Experience

With thousands of units in operation around the world, the DVSH is the preferred choice for applications requiring heavy-duty between bearings, single-stage, axially split pumps. Fully compliant with ISO 13709/API 610 (BB1), latest edition, the DVSH features the side/side nozzle configuration preferred in a broad range of applications. It is particularly well suited for use in process charge, transfer and pipeline services where uncompromising reliability over wide flow ranges is of utmost importance. Available in more than 80 distinct sizes, the DVSH provides the most comprehensive range of hydraulic coverage available, thereby permitting precise selection for best hydraulic fit, operating efficiency and stability.

Engineered Performance and Reliability

Consisting of a double-suction impeller operating in a heavy-duty double-volute casing, the DVSH's design inherently results in optimal axial and radial thrust balance over the pump's full operating range.

- Double-suction impeller provides axial hydraulic thrust balance and is designed for maximum hydraulic efficiency
- Double-volute design minimizes hydraulic radial loads, even at minimum flow
- Heavy-duty shaft design ensures trouble-free performance by operating under the first critical speed
- Extensive hydraulic coverage

Broad Applications

- Pipeline, booster and mainline
- Process charge
- Liquefied gas
- Power recovery
- Oil shipping
- Transfer
- Feed water or condensate booster

Complementary ISO 13709/API 610 Pumps Designs

Flowserve also offers the following complementary pumps:

- UZDL (BB1) axially split, two-stage
- HDX (BB2) radially split, single-stage, double-suction
- LPN (BB1) axially split, single-stage, double-suction
- DMX (BB3) axially split, multistage
- VPC (VS6) vertical turbine, double casing

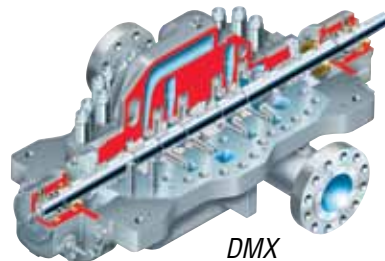

DVSH
Heavy-Duty,
Between Bearings,
Axially Split, Single-Stage
Double-Suction Pump
 ISO 13709/API 610 (BB1)

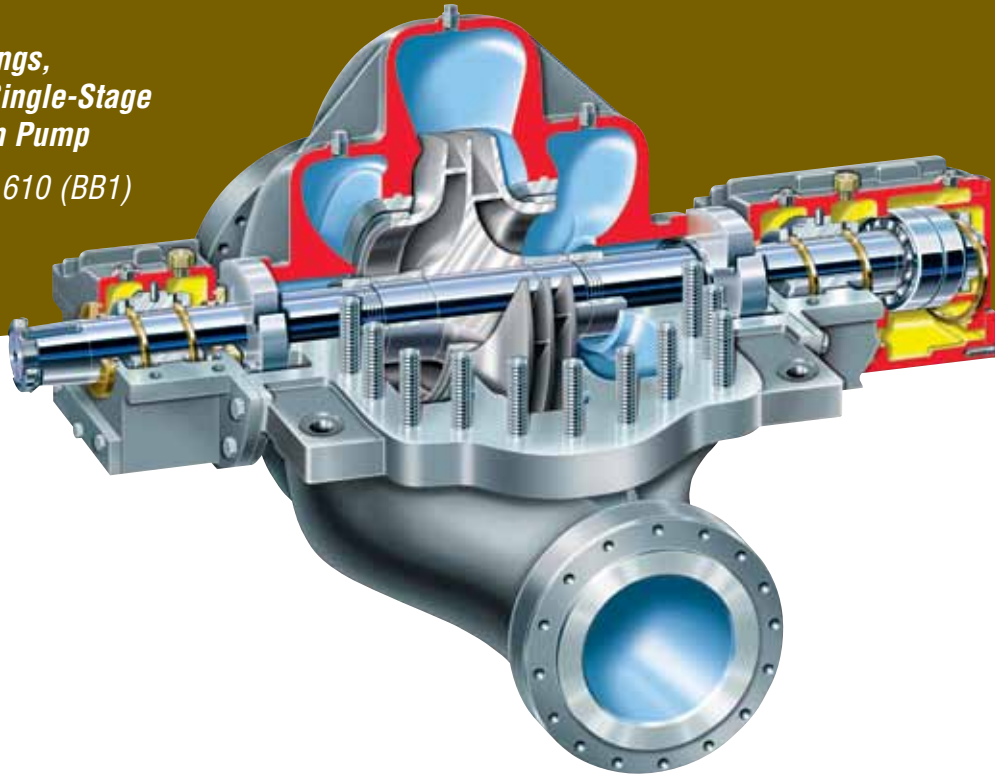

The Flowserve DVSH single-stage, double-suction pump is fully compliant with ISO 13709/API 610 (BB1), latest edition. It is engineered and built for heavy-duty applications commonly found in the oil and gas, water and power industries. Boasting comprehensive hydraulic coverage, it permits precise selection to ensure the best hydraulic fit and low total cost of ownership.

Operating Parameters

- Flows to 12 000 m³/h (53 000 gpm)
- Heads to 1850 m (565 ft)
- Pressures to 150 bar (2175 psi)
- Temperatures to 200°C (400°F)
- Specific gravities to 0.5
- Speeds to 6000 rpm

Features and Benefits

Double Volute, Axially Split Casing Design minimizes hydraulic radial forces in any condition down to the minimum flow, thereby reducing shaft deflection and increasing the life of bearings, seals and wear rings.

Suction and Discharge Nozzles are integrally cast in the lower casing half to permit pump disassembly without disturbing the piping. Nozzles are designed to handle external forces and moments equal to or in excess of ISO 13709/API 610 specifications.

Near Centerline Mounting provides superior pump alignment and performance at elevated temperatures.

Raised Face Flanges meet ASME B16.5 dimensional requirements. Class 600 (PN 100) flanges are standard; Class 900 (PN 160) and Class 1500 (PN 250) flanges are available to meet required operating pressures.

Double-Suction Impeller provides axial hydraulic thrust balance and allows minimal NPSHr. The impeller is dynamically balanced to assure vibration-free operation as per API/ISO requirements.

API 682/ISO 21049 Seal Chambers ensure ample flow around the seal faces and allow for installation of cartridge style single, dual unpressurized and dual pressurized mechanical seals to meet required safety and environmental requirements. Covers optional.

Heavy-Duty Shaft Design ensures trouble-free operation below the first critical speed. Large diameter shaft and short bearing span minimize deflection. Options include double extension for connection to auxiliary pumps or hydraulic turbines, and special shaft end machining for hydraulic fitted couplings.

Standard Renewable Casing and Impeller Wear Rings provide hydraulic stability and high operating efficiency. They also ensure proper thrust loading on bearings. Optional laser hardened or non-metallic wear rings in Graphalloy®, PEEK® and other materials are available.

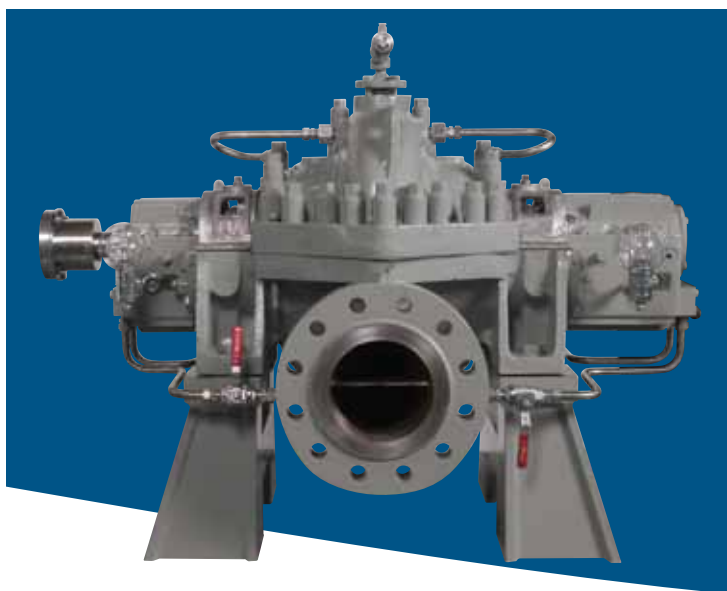

Multiple Bearing Designs

The DVSH is offered with a variety of bearing designs to meet application requirements. The standard radial bearings are single row, self-aligning, antifriction type. Thrust bearings also are antifriction type and are double row mounted back-to-back.

Optional bearing designs include the following:

- Split sleeve radial and ball thrust
 - Typically applied to energy density (= power x rated speed) ratings up to 4.0 million (= kW x rpm) or 5.4 million (= hp x rpm).
 - Standard for applications where thrust bearing speed and life for rolling element bearings are within ISO 13709/ API 610 limits.
- Split sleeve radial and tilting pad thrust with force feed lubrication
 - Applied when energy density ratings and bearing speed or life is beyond the limits for rolling element bearings as defined by ISO 13709/API 610.
 - Tilting pad thrust bearings require an external forced feed lubrication system. Pump shaft driven or separate lube pumps available.

Flowserve engineers will help select the optimal construction based on ISO/API specifications, the application and the speed and horsepower rating of the pump.

Bearing Housing

The DVSH's carbon steel bearing housing features 180° bolting and heavy-duty mounting brackets to facilitate maintenance. Labyrinth seals are standard; bearing isolators available.

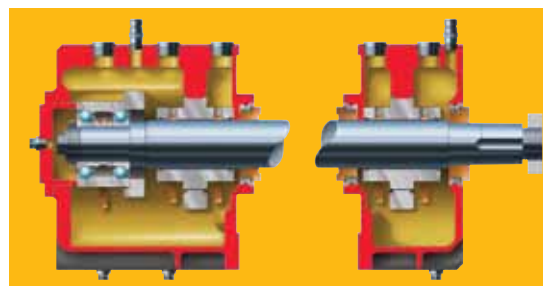

Split Sleeve Radial and Ball Thrust

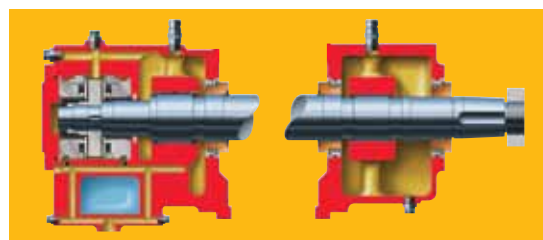

Split Sleeve Radial and Tilting Pad Thrust

© Graphalloy is a registered trademark of the Graphite Metallizing Corporation.

© PEEK is a registered trademark of Victrex Plc Corp.

Options and Technical Data



Pump Packages

Pump packages are provided to specification and include lube oil piping, seal system, monitoring instruments and drive train mounting.

Baseplate Designs

Engineered to contract requirements, baseplate designs may include any of the following:

- Conventional welded steel with drain rim; suitable for grouting
- Skid-type, non-grouted
- Three-point support design

Pumps mounted with engine or turbine drivers as well as multiple pump modules also are available.

Available Radially Split Design

The DVSH is available in a radially split configuration called the DVSR (see above). This design is preferred for applications at very high pressures or low specific gravity, such as liquefied gases including CO₂.

Standard Testing and Balance

- A certified hydrotest is performed on each casing.
- Final two plane dynamic balancing and TIR verifications are conducted on every assembled rotor.
- Performance and vibration testing assure optimum mechanical performance throughout the entire operating range.

DVSH Range Chart

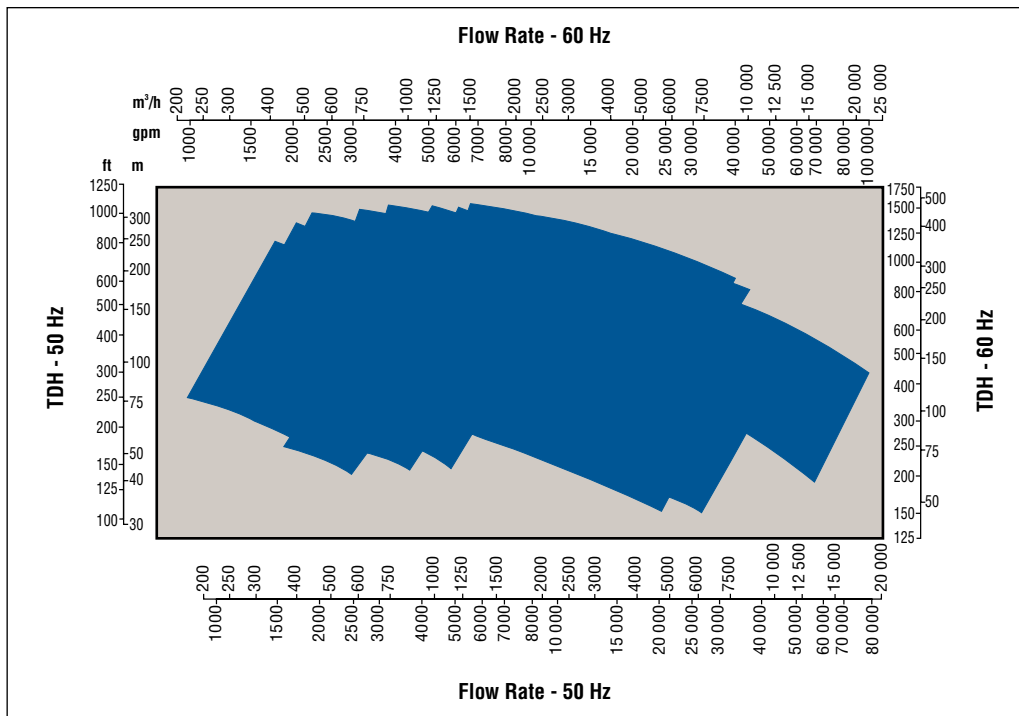

Global Service and Technical Support



Life Cycle Cost Solutions

Typically, 90% of the total life cycle cost (LCC) of a pumping system is accumulated after the equipment is purchased and installed. Flowserve has developed a comprehensive suite of solutions aimed at providing customers with unprecedented value and cost savings throughout the life span of the pumping system. These solutions account for every facet of life cycle cost, including:

Capital Expenses

- Initial purchase
- Installation

Operating Expenses

- Energy consumption
- Maintenance
- Production losses
- Environmental
- Inventory
- Operating
- Removal

Innovative Life Cycle Cost Solutions

- New Pump Selection
- Turnkey Engineering and Field Service
- Energy Management
- Pump Availability
- Proactive Maintenance
- Inventory Management

Typical Pump Life Cycle Costs¹

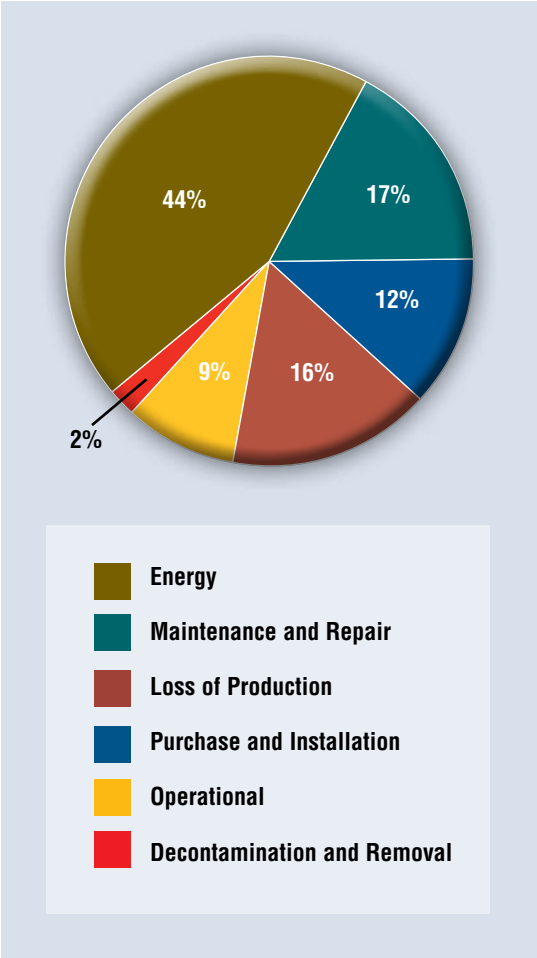

¹ While exact values may differ, these percentages are consistent with those published by leading pump manufacturers and end users, as well as industry associations and government agencies worldwide.

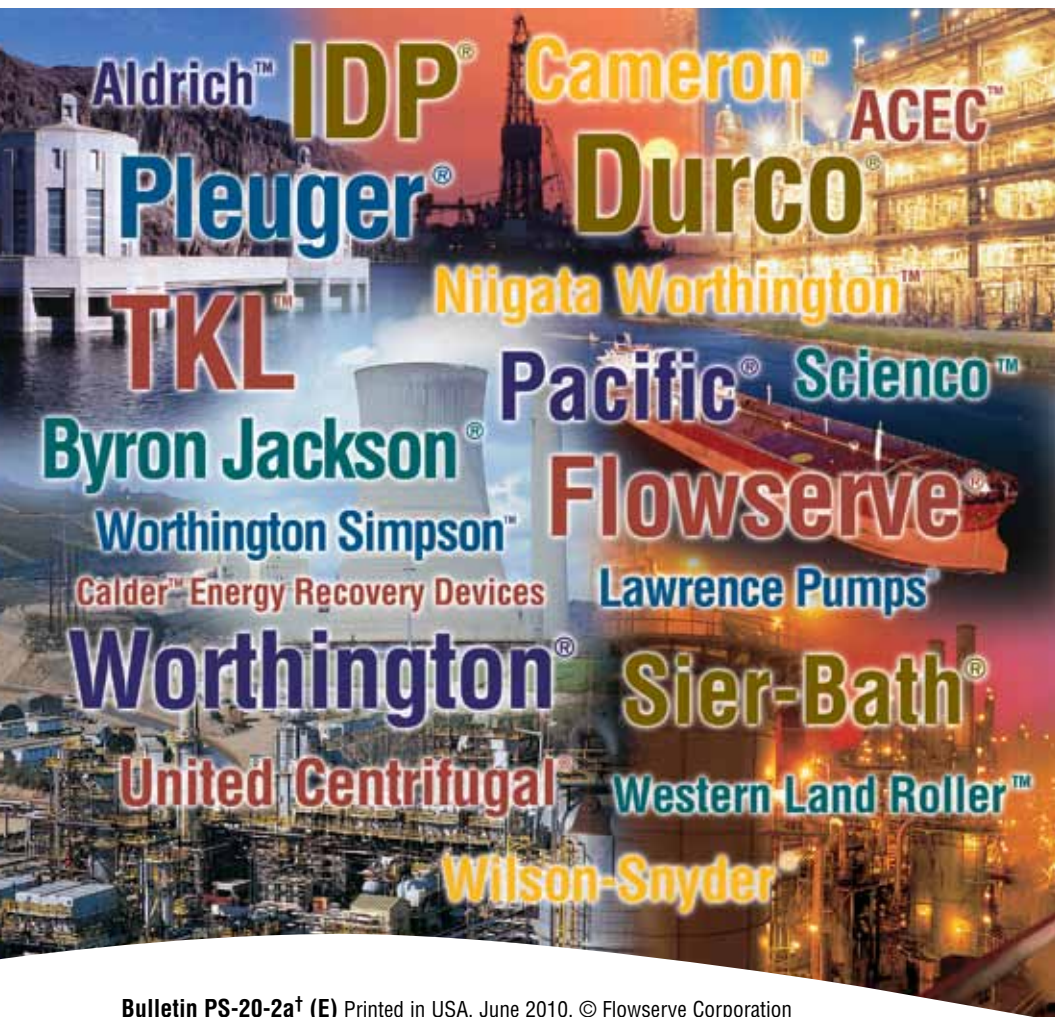

USA and Canada
Flowserve Corporation
5215 North O'Connor Blvd.
Suite 2300
Irving, Texas 75039-5421 USA
Telephone: 1 937 890 5839

Europe, Middle East, Africa
Flowserve Corporation
Gebouw Hagepoint
Westbroek 39-51
4822 ZX Breda
Netherlands
Telephone: 31 76 502 8920

Latin America
Flowserve Corporation
Martín Rodríguez 4460
B1644CGN-Victoria-San Fernando
Buenos Aires, Argentina
Telephone: 54 11 4006 8700
Telefax: 54 11 4714 1610

Asia Pacific
Flowserve Pte. Ltd.
10 Tuas Loop
Singapore 637345
Telephone: 65 6771 0600
Telefax: 65 6779 4607

Bulletin PS-20-2a† (E) Printed in USA. June 2010. © Flowserve Corporation

To find your local Flowserve representative:

For more information about Flowserve Corporation,
visit www.flowserve.com or call USA 1 800 728 PUMP (7867)